

# Data sheet Mobile Cobot Lift

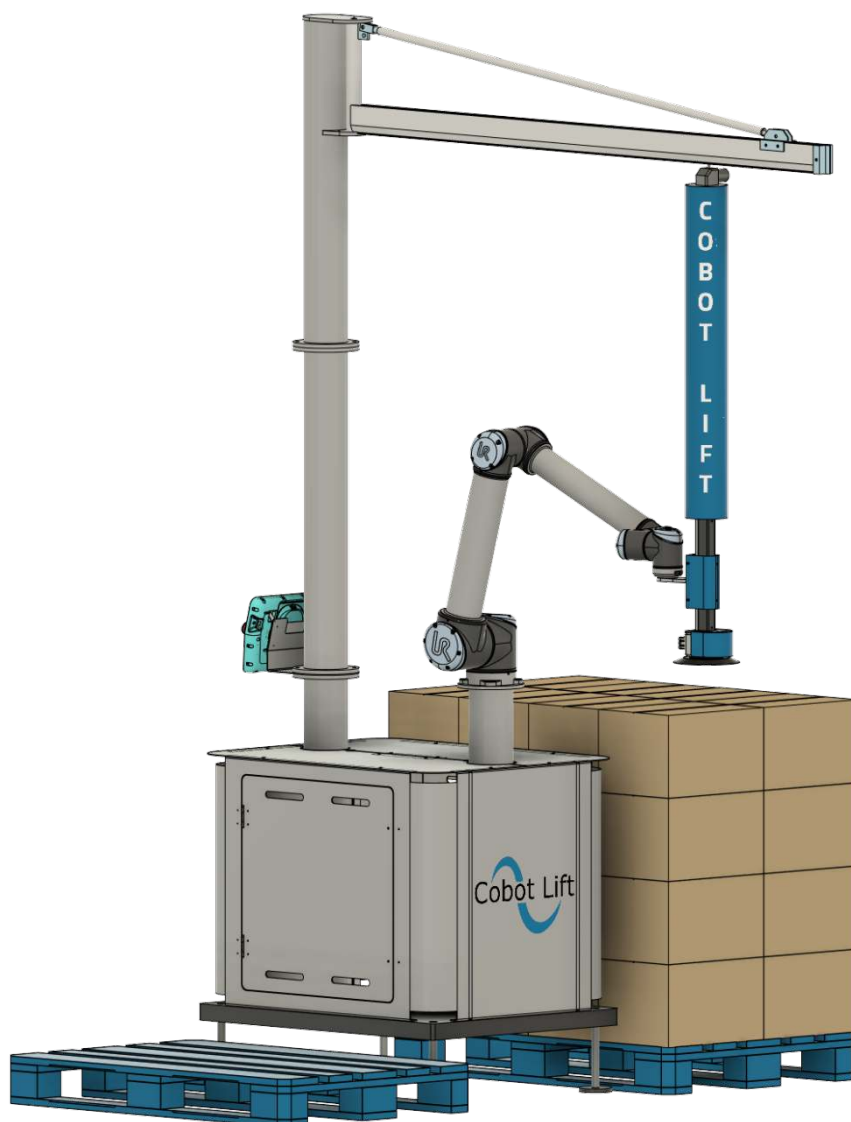

## Contact

Cobot Lift ApS | Industrivej 6 | 4200 Slagelse

+45 30 72 14 60 | CVR 39510693 | [info@Cobotlift.com](mailto:info@Cobotlift.com)

Payload	5-30 kg
Weight of complete solution	Approx. 600 kg
Reach	Up to 1400 mm
Degree of freedom	4
Power Supply	380-440V/16 Amp 230V/16 Amp
Air supply	5-8 bar
Stacking height	Max 1600 mm (depending on product and reach)
Robot position height	Approx. 120 cm
Dimensions – complete solution with Cobot Lift, vacuum tube lift and UR arm	Footprint (80x100 cm), height of crane 3,2 meter
Certifications and standards	Declaration of Incorporation Directive 2006/42 EC, Annex II B
Collaborative Robot, Compatibility	UR10 CB3 or e-series
Software version required	Min. 3.5 or e-series
Programming	Cobot Lift URCap in Polyscope
Vacuum tube lifter	Approx. 120mm vacuumtube and 3KW vacuumpump
Main material	Steel
Accessories	Suction foot for sacks Suction cup for boxes and buckets Quick connector for end effector

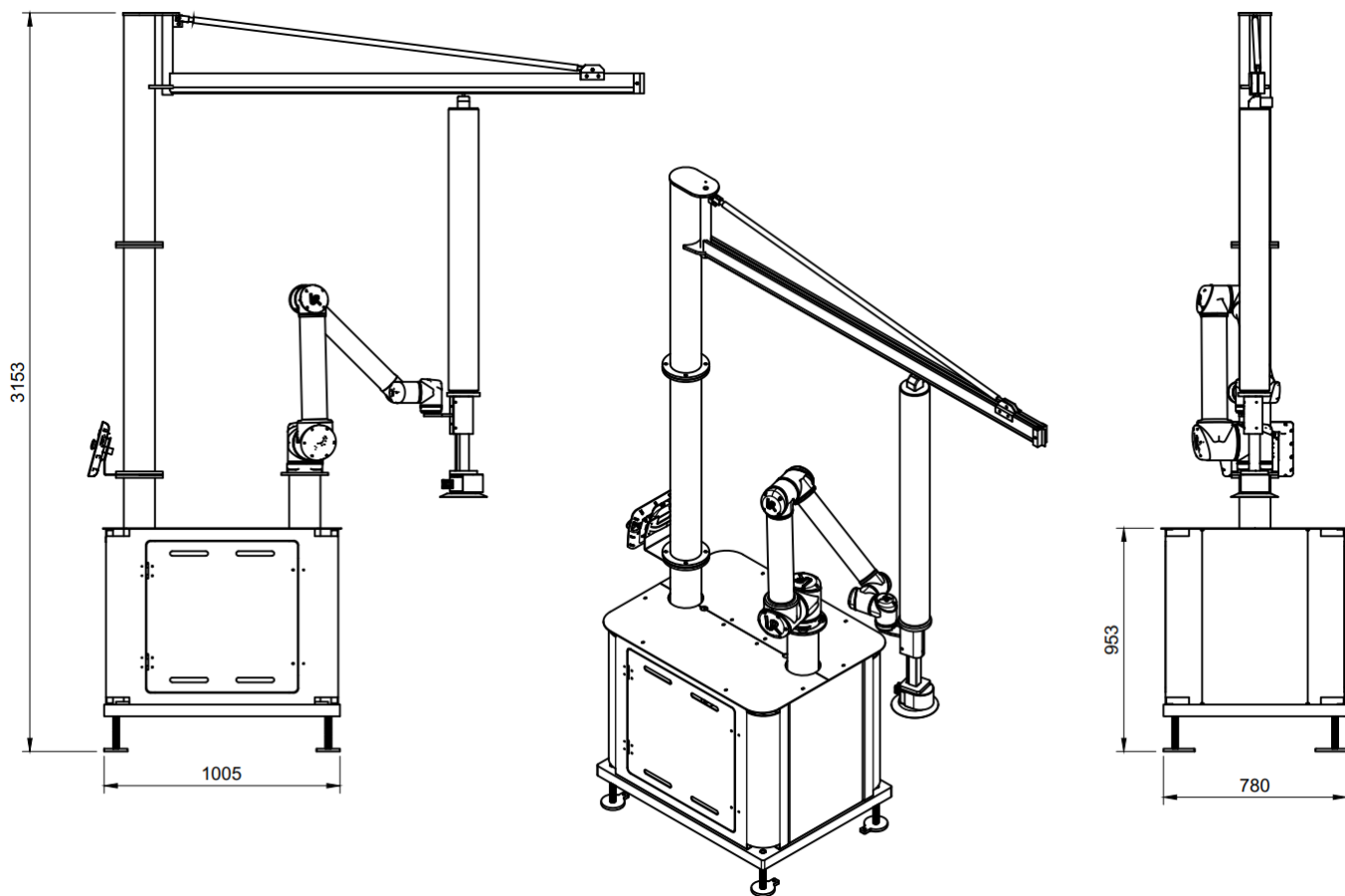

Radius for UR10 & tool

Radius for crane

