

# Data sheet Stationary Cobot Lift

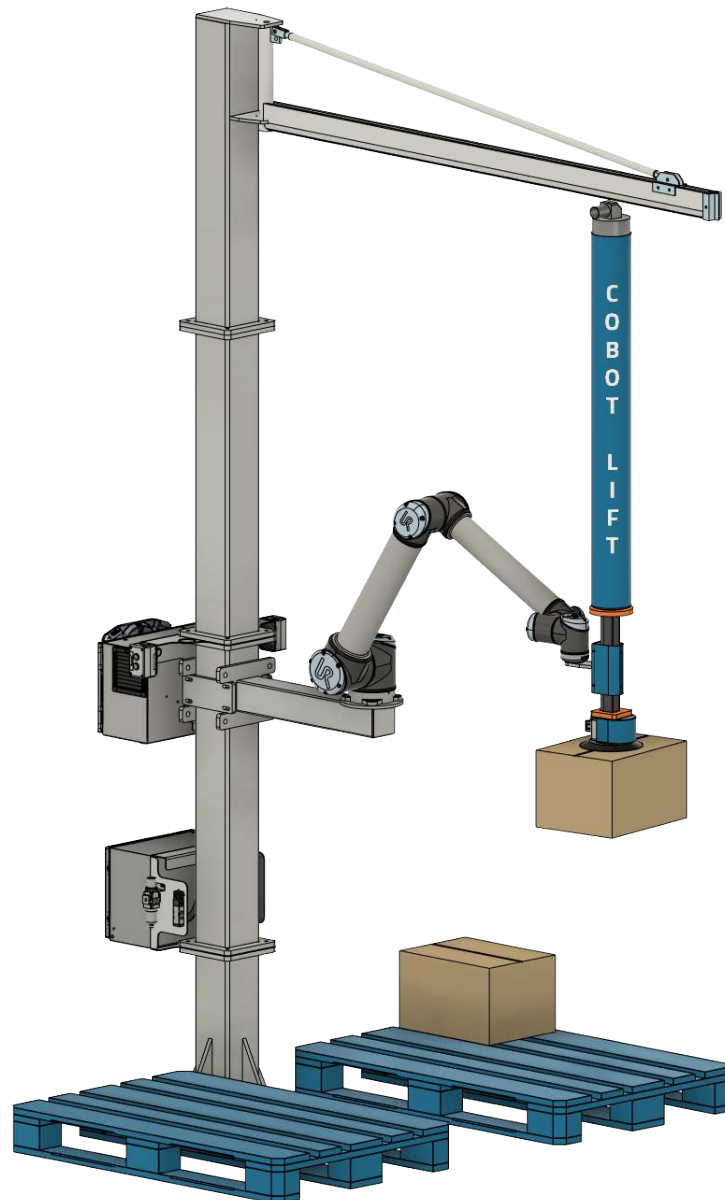

## Contact

Cobot Lift ApS | Industrivej 6 | 4200 Slagelse  
+45 30 72 14 60 | CVR 39510693 | [info@Cobotlift.com](mailto:info@Cobotlift.com)

Payload	5-30 kg
Weight of complete solution	Approx. 250 kg
Reach	Up to 1400 mm
Degree of freedom	4
Power Supply	400V/16 Amp 230V/16 Amp
Air supply	5-8 bar
Stacking height	Max 1600 mm (depending on product and layout of robot cell)
Robot position height	The arm on which the Cobot is placed can be adjusted from 700-1400 mm , extra crane module of 0.5mtr length incl. for more flexibility
Dimensions – complete solution with Cobot Lift, vacuum tube lifter and UR arm	Footprint of crane, 40x40 cm, Standard height of crane 3,5 meter
Certifications and standards	Declaration of Incorporation Directive 2006/42 EC, Annex II B
Collaborative Robot, Compatibility	UR10 CB3 or e-series
Software version required	Min. 3.5 or e-series
Programming	Cobot Lift URCap in Polyscope
Vacuum tube lifter	120mm vacuumtube and 3 kW vacuum pump
Main material	Steel
Accessories	Suction foot for sacks Suction cup for boxes and buckets Quick connector for end effector Silencer box for vacuum pump

