

ENGINEERING MANUAL

Fast & Simple to Use
Online Configurator

Innovative Timing Belt
Conveyor Design

Industry Best
Pallet Transfer System

Clean Room Class
100 Certified

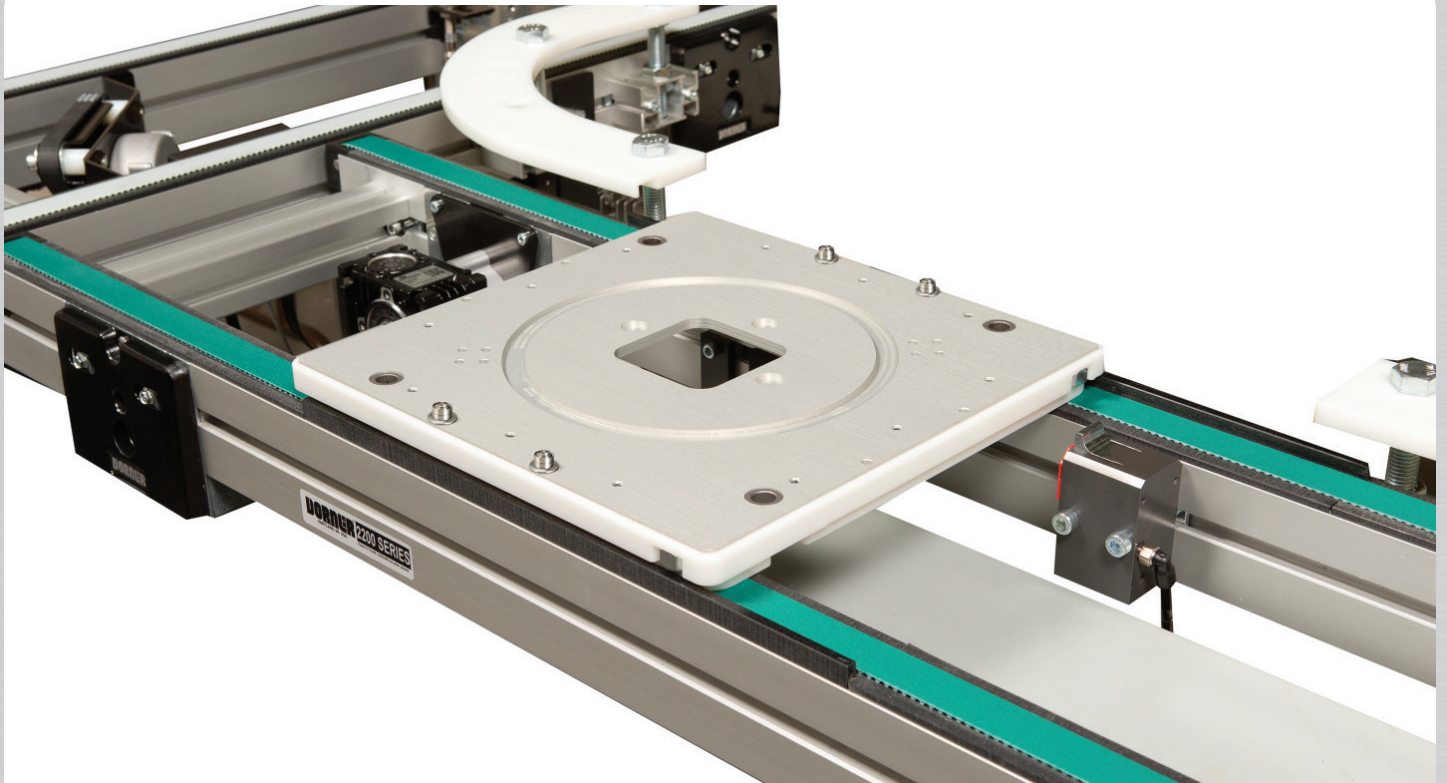

2200 SERIES PRECISION MOVE

PALLET SYSTEMS

Innovative, Modular, Dual Belt Conveyor
Pallet Systems for Assembly Automation

DORNIER 

Innovative Lifting Modules

- Lift and Locate:
 - Adjustable height lift from center of conveyor
 - Provides 200 lbs of lift capability at 90 psi
 - Accuracy of ± 0.002 "
- Lift and Rotate:
 - Pneumatic lift from center of conveyor
 - Pneumatic rotation with adjustable positioning
 - Rotation angle: 90 to 180 degrees adjustable
 - Includes cushioned lift stroke
- Lift and Transfer:
 - Changes product orientation
 - Uses dual strand timing belt conveyors and pneumatic lift
 - 70 lbs load capacity

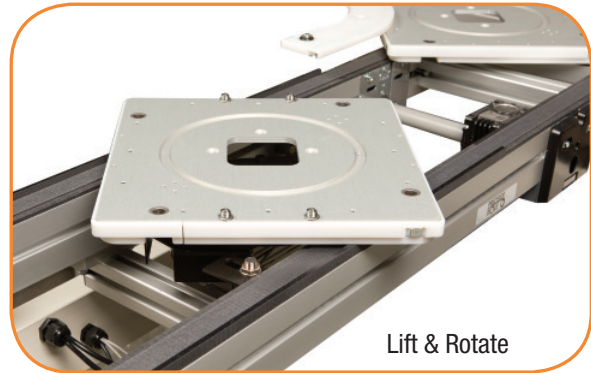

Simple Powered Corner Modules

- 90 Degree Corner:
 - Uses pin tracking in pallet
 - Maintains product orientation through the turn
 - Includes 24VDC drive mechanism to drive the pallet around the corner
- 90 Degree Corner and Merge:
 - Uses pin tracking in pallet
 - Inside guide is mounted to pneumatic cylinders to transfer pallet around corner
 - Straight guide with pneumatic cylinder is mounted across perpendicular conveyor to guide pallets straight through the merge area
 - Includes 24VDC drive mechanism to drive the pallet around the corner

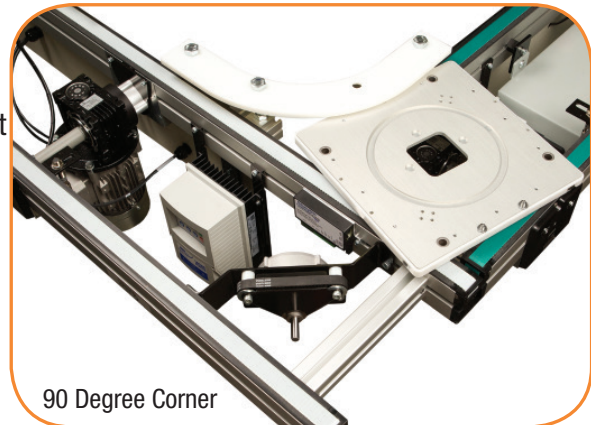

Accurate Pin Tracking System

- Simple and cost effective method of tracking pallets through turns
- Used on 90 Degree Corner and 90 Degree Corner & Merge Modules



The Benefits of a Dorner 2200 Series Precision Move Pallet System

Innovative Offering

- Timing belt conveyors provide added load capacity in a small platform
- Quick belt change without the need to remove conveyor from system
- Pin Tracking System provides cost effective pallet traffic management

Delivers Fast

- Dorner sets the industry standard for rapid delivery
- Conveyors and automation modules available in 20 days or less

Time Saving

- Dorner's online configurator engineers simple to complex configurations in minutes.
- The industry leading tool delivers a complete 3D Assembly model for instant validation of fit

CONTROLLERS & MOTORS STARTERS
PAGES 41-42

CONVEYOR
PAGES 8-9

TRAFFIC CONTROLS
PAGES 28-34

BELTING
PAGE 37

HEAVY LOAD 90 & 180 DEGREE CORNER
PAGES 24-25

90 DEGREE CORNER
PAGES 20-21

180 DEGREE CORNER
PAGES 22-23

90 DEGREE CORNER & MERGE
PAGES 26-27

PALLETS
PAGES 10-11

LIFT & ROTATE
PAGES 18-19

LIFT & LOCATE
PAGES 12-15

SUPPORT STANDS
PAGE 43

GEARMOTORS
PAGES 38-40

ACCESSORIES
PAGES 44-47

ENGINEERED SOLUTIONS
PAGES 35-36

EXAMPLE LAYOUTS
PAGES 6-7

TECHNICAL DATA & CALCULATIONS
PAGES 48-58

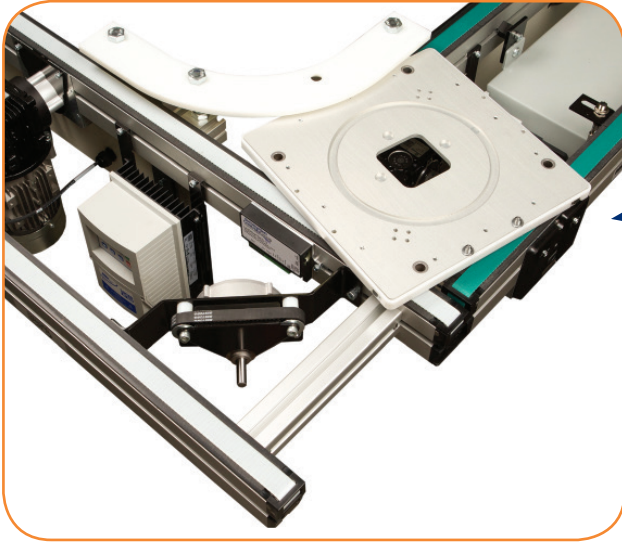

INNOVATIVE CORNERS:

THE CORNER SYSTEMS IN CONJUNCTION WITH THE PALLET PIN TRACKING PROVIDE A SIMPLE, COST EFFECTIVE MEANS FOR PALLET TRAFFIC CONTROL.

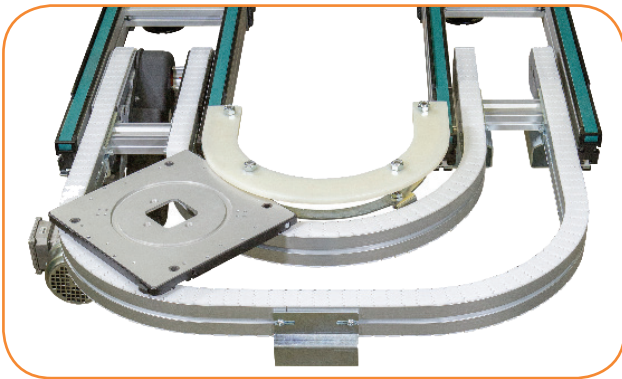

HEAVY LOAD CORNERS:

THE HEAVY LOAD CORNERS PROVIDE THE CAPABILITY TO TRANSPORT LOADS TO 150 LBS AND ACCUMULATE PALLET IN THE CORNER.

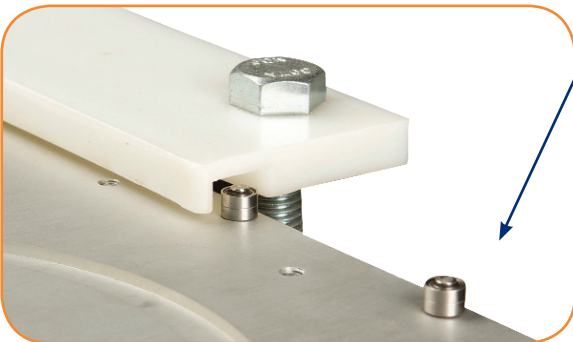

PIN TRACKING SYSTEM:

THE OPTIONAL PALLET PIN TRACKING SYSTEM PROVIDES PALLET TRAFFIC CONTROL THROUGH CORNERS AND MERGES.

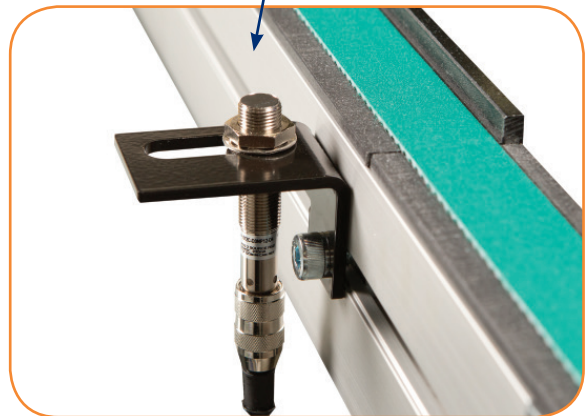
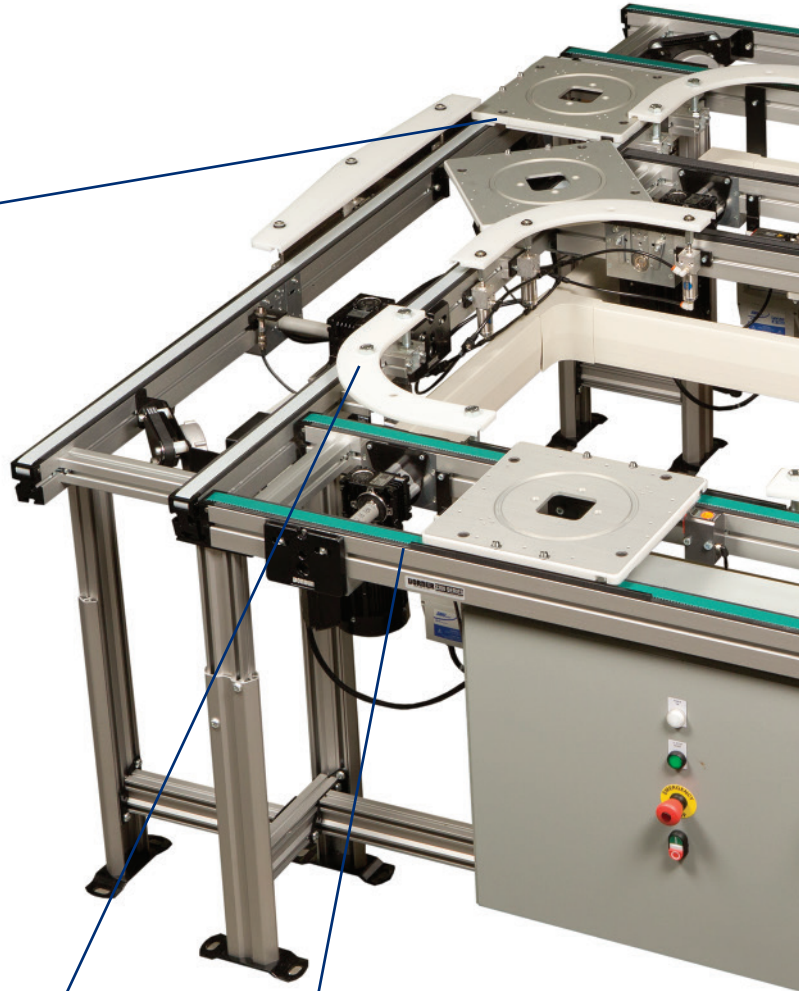

UNIVERSAL T-SLOT:

CONVEYOR T-SLOT IS COMPATIBLE WITH DORNER 2200 SERIES AND SMARTFLEX® T-SLOT HARDWARE ALONG WITH SELECT INDUSTRY STANDARD 10 MM SLOT HARDWARE.

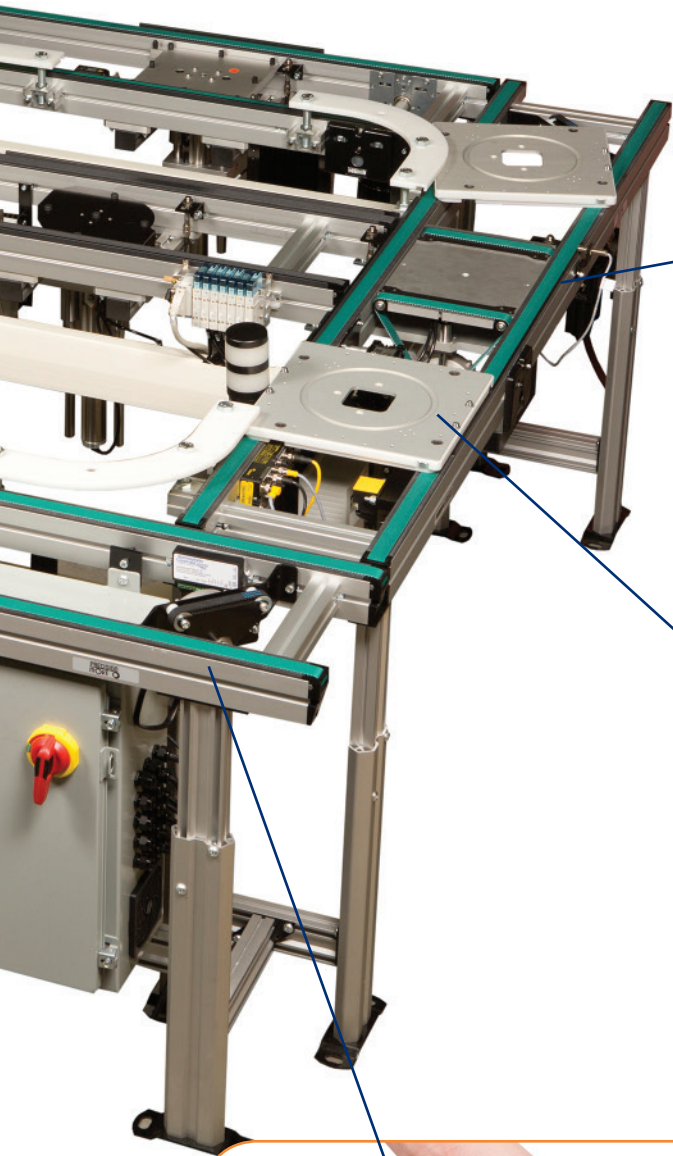

TIMING BELT CONVEYOR:

25 MM WIDE T5 TIMING BELT PROVIDES HIGH STRENGTH AND LARGE LOAD CAPACITY IN A COMPACT PACKAGE.

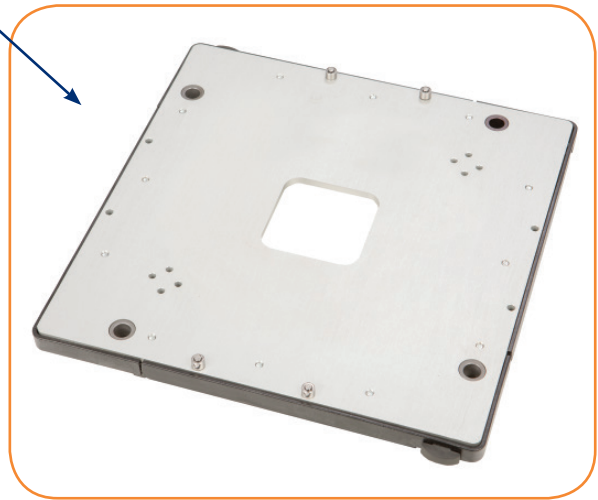

INDUSTRY COMPATIBLE PALLETS:

PALLETS AVAILABLE IN INDUSTRY STANDARD SIZES ALONG WITH LOCATION PINS THAT ARE COMPATIBLE WITH INDUSTRY STANDARD PALLETS AND LOCATE STATIONS.

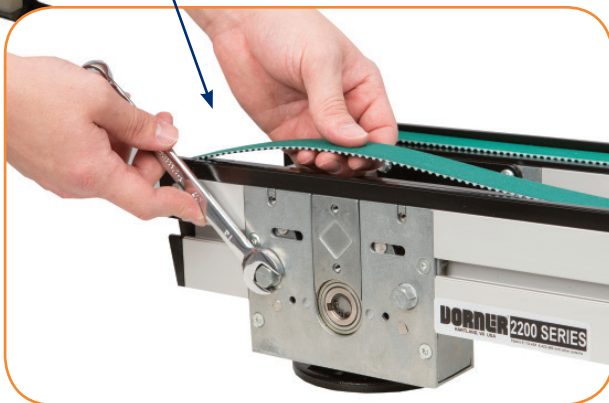

QUICK BELT CHANGE:

TOP REMOVAL BELT CHANGE METHOD PROVIDES QUICK BELT MAINTENANCE ACCESS WITHOUT THE NEED TO REMOVE THE CONVEYOR OR SURROUNDING AUTOMATION COMPONENTS.

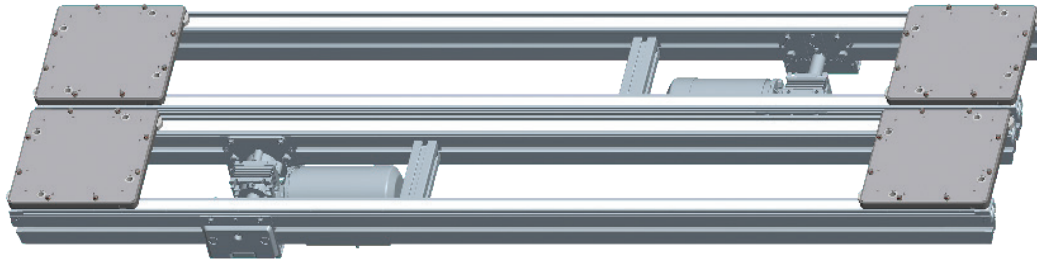

Loop with Close Transfer

Main lines are spaced tightly together to remove transverse conveyors.

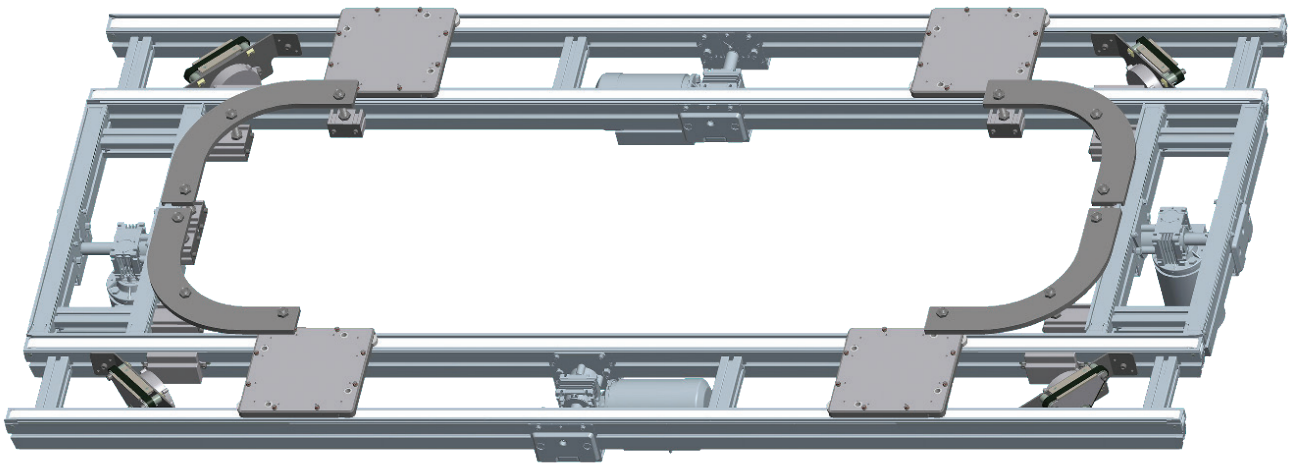

Loop (Racetrack)

Leading edge orientation is maintained using 90 degree corners.

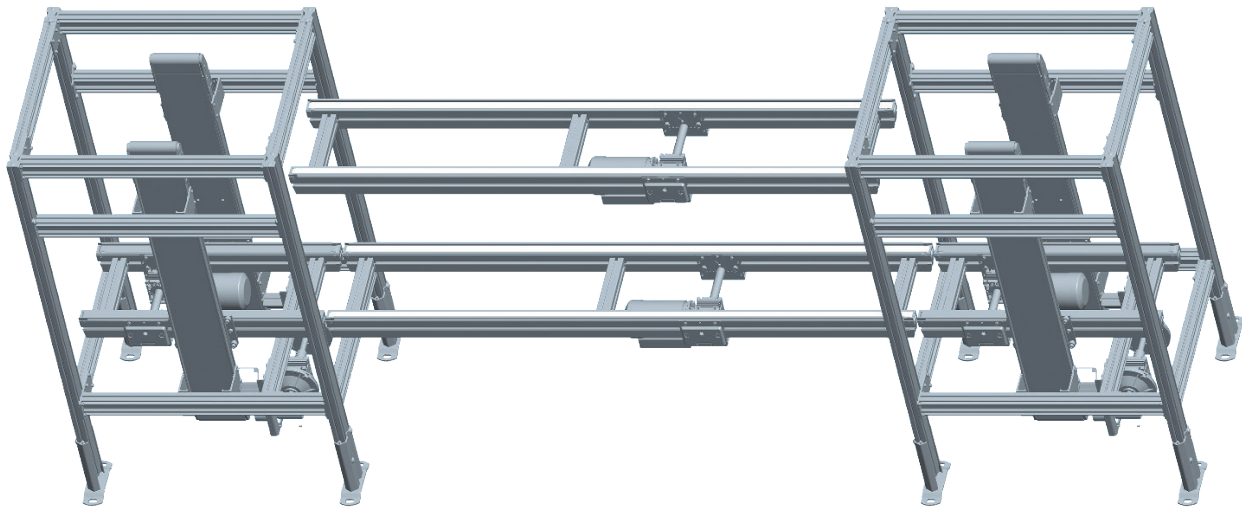

Over Under

The return line is located under the main line. Vertical Transfer Units (Elevator) raise and lower the pallets on the ends.

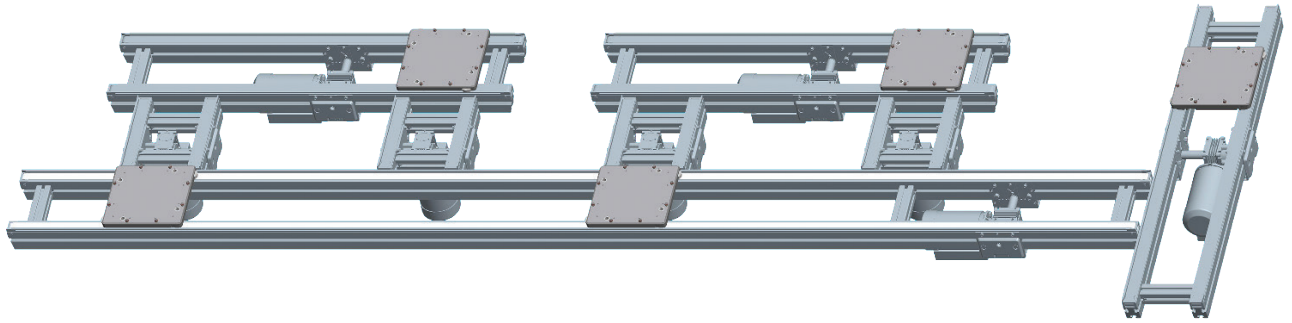

Satellite Loop

Satellite loops provide workstation loops off the main line for operators or machine interface.

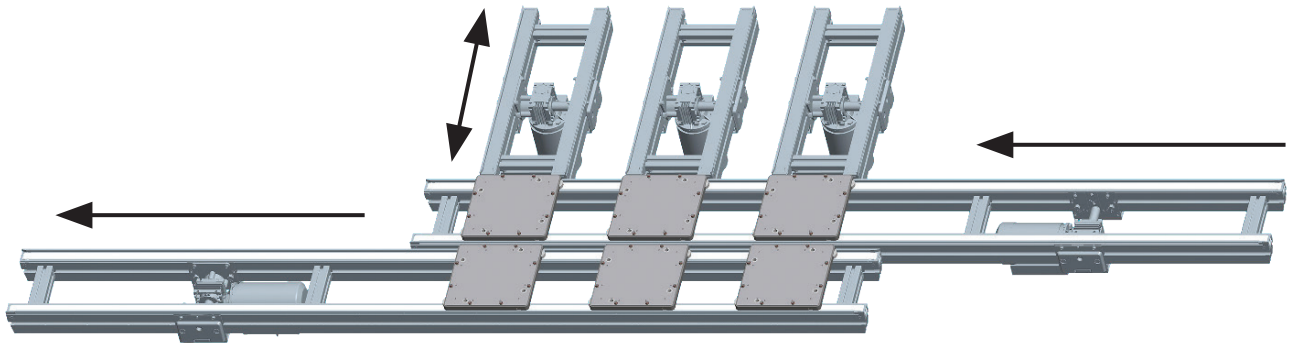

Spur Line

The product flow in this example is from right to left. The pallet travels along the upper main line then transfers into 1 of the 3 parallel operations on the vertical spur lines. When the operation is complete the spur line reverses direction and the pallet transfers over the upper main line onto the bottom main line for finished processing.

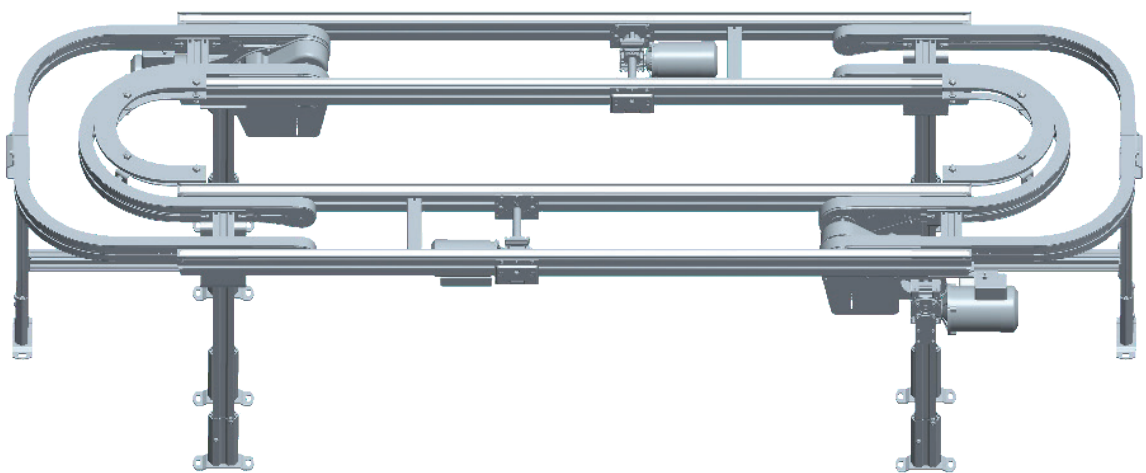

Heavy Load Loop

Tight radius turns maintain leading edge orientation while keeping the main lines closely spaced to reduce the overall footprint. Heavy load corners allow pallet accumulation in the corners.



Idler End

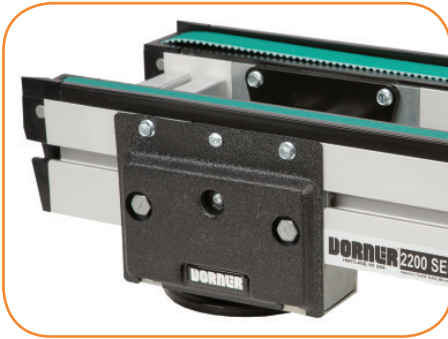

Drive End

Specifications

- 25 mm wide belting
- Overall width:
 - Width is defined by the pallet width
 - Nominal widths (mm) 160, 240, 320, 400, 480
- Custom widths available. Consult factory for non-standard widths and widths over 480 mm.
- Lengths: 11" to 24' 7" (275 mm to 7500 mm) long, in 5 mm increments
- Load Capacity: 500 lbs (227 kg) non-accumulating, 250 lbs (113 kg) accumulated
- Belt speeds to 114 ft/min (35 m/min)
- Bi-directional belt at full load capacity
- Belts: T5 timing belts with steel cords
 - Medium Friction, Low Friction, and Static Conductive Low and Medium Friction available
- 40 Tooth, 2.51 in (63.69 mm) pitch diameter drive sprocket
- 0.90 in diameter end rollers
- Mid Drive is available in any location along the conveyor rails starting at 30 mm from each end
- Quick belt change design allows changing of conveyor belt without removal of conveyor or automation devices
- Conveyor T-Slot located on bottom and both sides. Compatible with Dorner 2200 Series and SmartFlex® T-Slot hardware along with select industry standard 10 mm slot hardware.

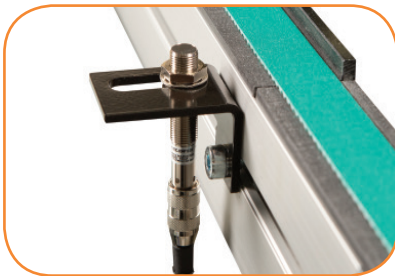

**STANDARD FEATURE:
Universal T-Slot
Compatible with Industry
Standard 10 mm hardware**

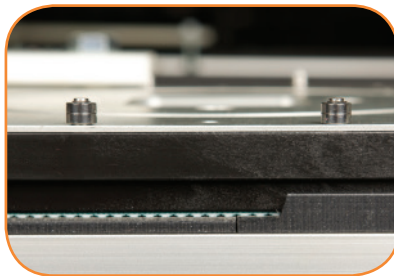

**STANDARD FEATURE:
Interchangeable Low Side**

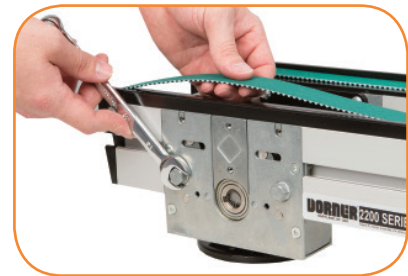

**STANDARD FEATURE:
Quick belt change
without the removal of
conveyor or accessories**

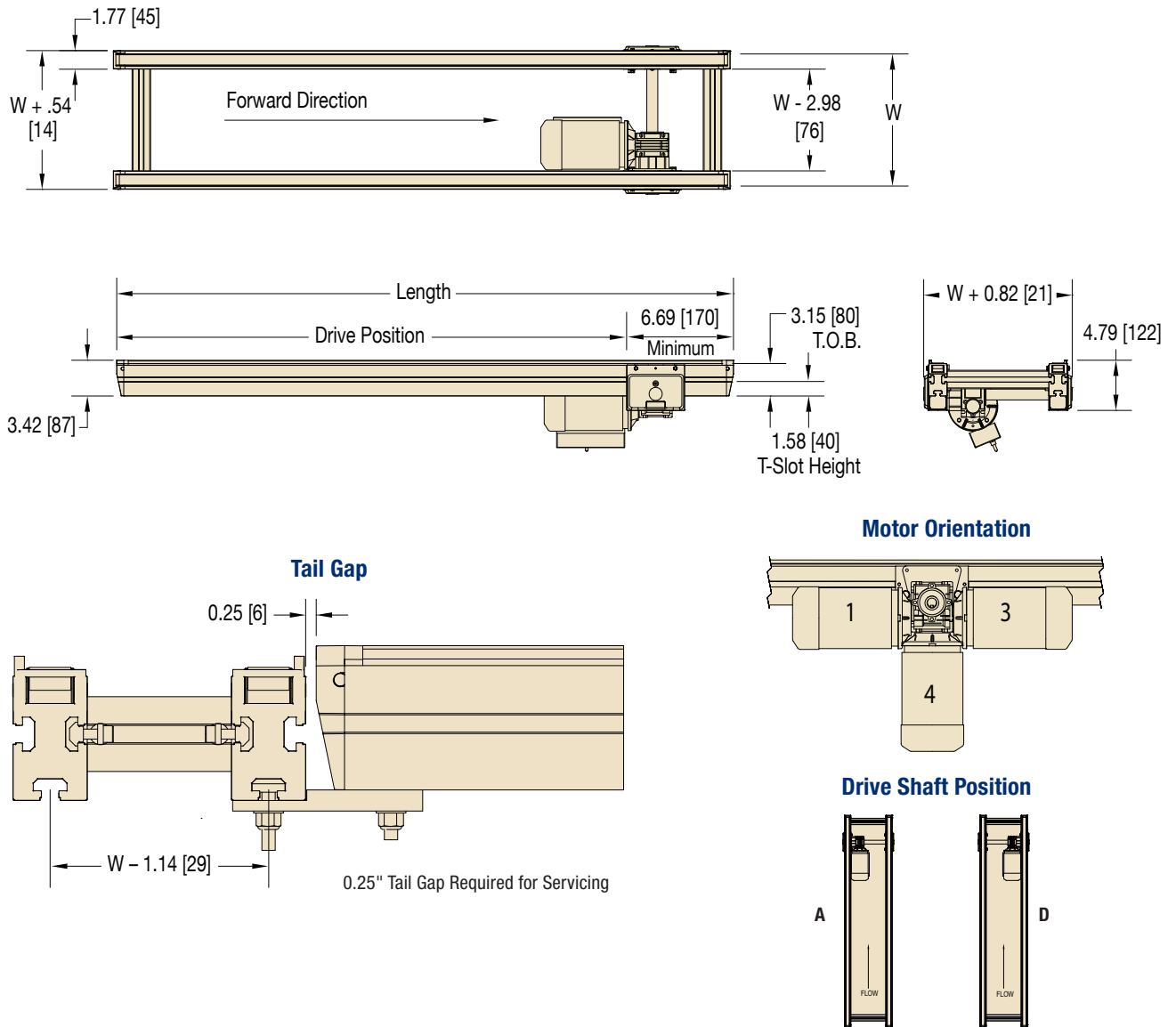

2200 Series Precision Move: Dual Strand Conveyor

2 2 D S C M WWW - L L L L M O G - P P P B B

Belt Type: 1D = Low Friction 2D = Med Friction 6D = ESD Low Friction

Drive Position: PPPP in millimeters from infeed 0030 - 7330

Gearmotor type: S = Standard load E-drive* H = Heavy load E drive C = CE standard load E-drive

Motor Orientation: 1 = Position 1 (horizontal leading) 3 = Position 3 (horizontal trailing) 4 = Position 4 (vertical down)

Motor Side: A = A Side D = D Side

Conveyor Length Reference: LLLL in millimeters 0275 - 7500 (in 5 mm increments)

Conveyor Width Reference: 160 = 160 mm 240 = 240 mm 320 = 320 mm 400 = 400 mm 480 = 480 mm

Documentation Language: M = US-English

Conveyor Type: C = Mid Drive Conveyor - Center Drive Position from Infeed

* 160 mm width available on standard load E-drive only

Note: Due to the wide variety of drive setups and applications, point of installation guarding is the responsibility of the end user.

Note: Dimensions = in (mm)

Specifications

- Pallet is dimensionally compatible with industry standards
- Pallet Base:
 - Anodized aluminum tool plate is standard (other materials available, contact factory)
 - Thicknesses of 3/16" to 1/2"
- Pallet Skirt Material: Electrostatic Dissipative HPDE
- Includes (4) hardened bushings for Lift and Locate
- Optional Ball Bearing Pin Tracking used for pallet tracking at corners
- Plated Steel Proximity Sensor pick-up on bottom and side of pallet
- Optional pallet bumpers for noise and impact reduction
- Custom widths available
- Center of gravity of the combined payload should be located in the center third of the pallet

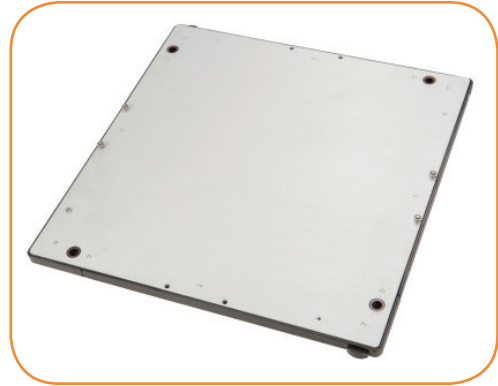

Pallet Sizes		Length (mm)					
		160	240	320	400	480	640
Width (mm)	160	X	X				
	240	X	X	X		X	
	320		X	X		X	
	400				X	X	
	480		X	X	X	X	CF
	640					CF	CF

Total Load Capacity including Pallet, Fixture and Product:		Length (mm)					
		160	240	320	400	480	640
Width (mm)	160	30 lbs	40 lbs				
	240	40 lbs	50 lbs	60 lbs		70 lbs	
	320		60 lbs	70 lbs		70 lbs	
	400				70 lbs	70 lbs	
	480		70 lbs	70 lbs	70 lbs	70 lbs	CF
	640					CF	CF

CF = Consult the Factory for availability and total load capacity



Optional Pallet Bumpers



Optional Ball Bearing Pin Tracking

2200 Series Precision Move: Pallets

2 2 D S P M W W W - L L L A T P

- Pin Tracking System: 0 = Without Pin Tracking System 1 = Single Side Pin Tracking System
2 = Dual Side Pin Tracking System 4 = 4 Side Pin Tracking System
- Plate Thickness: 3 = 3/16" 4 = 1/4" 6 = 3/8" 8 = 1/2"
- Pallet Options: A = Assembled with aluminum top plate
B = Assembled with aluminum top plate and bumper on two ends
C = Kit only without aluminum top plate
D = Kit only without aluminum top plate, includes bumper on two ends
- Pallet Length Reference: 160 = 160 mm 240 = 240 mm 320 = 320 mm 400 = 400 mm 480 = 480 mm
- Pallet Width Reference: 160 = 160 mm 240 = 240 mm 320 = 320 mm 400 = 400 mm 480 = 480 mm
- Documentation Language: M = US-English
- Conveyor Type: P = Pallet

*Note: Pallet bumper cannot be used in applications where pallets slide against each other.

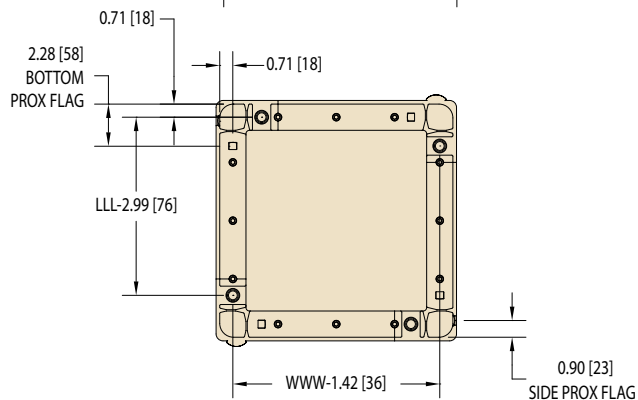
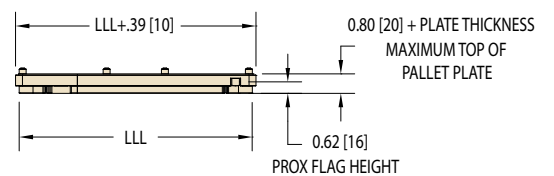
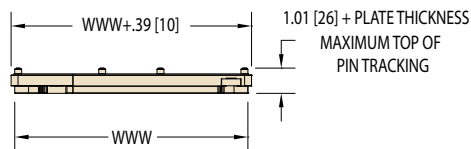
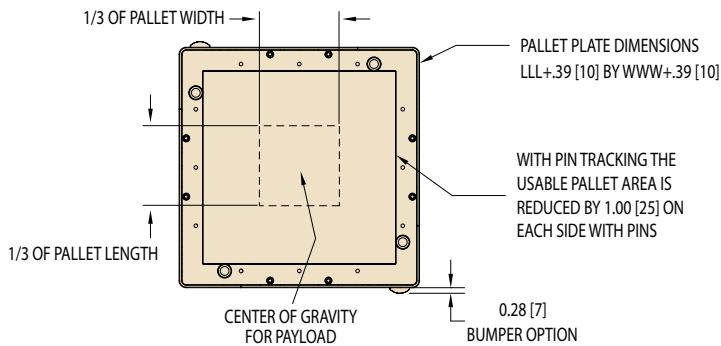
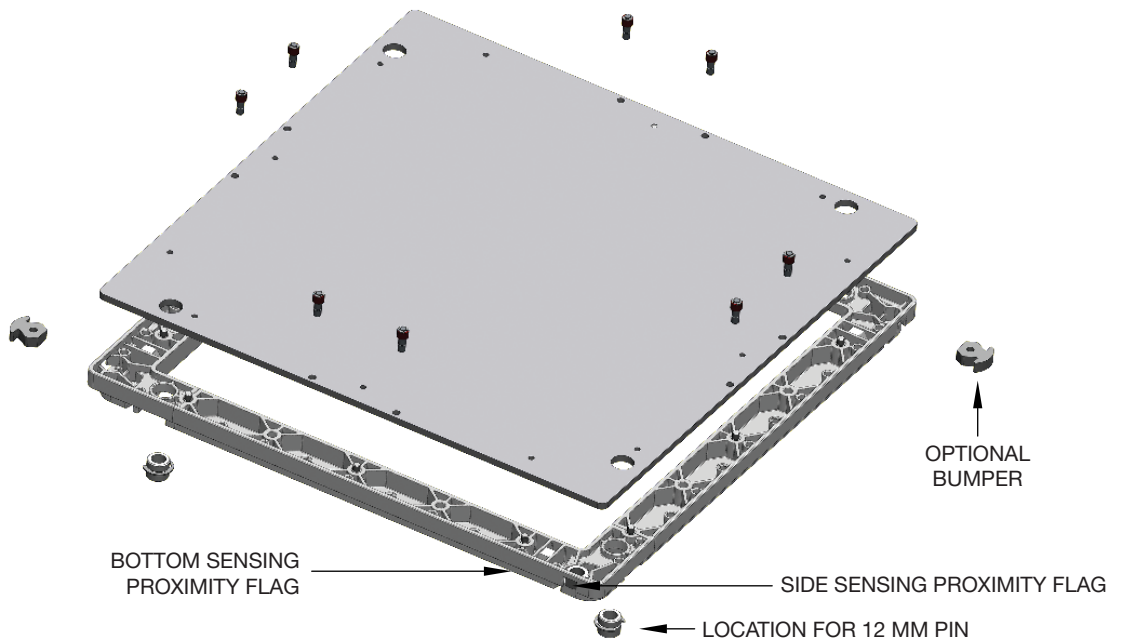

See page 54 & 58 for detailed pallet weights and detailed pallet plate drawings.

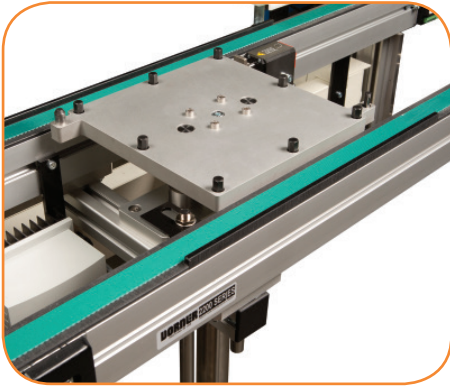
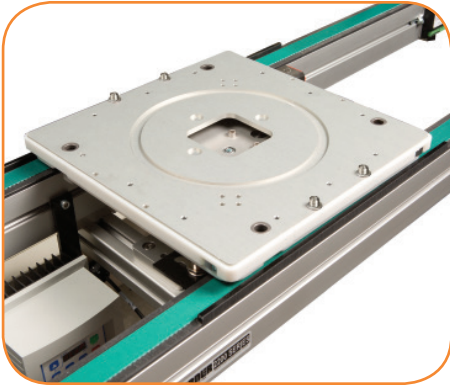

Specifications

- Lifts from center of conveyor
- Provides 200 lbs (91 kg) of lift capability at 90 psi
- Repeatability of ± 0.002 "
- Lift height is adjustable, maximum height is 2" from top of belt to bottom of pallet
- Includes cushioned lift stroke
- Includes lift, pallet stop, mounting hardware and fittings for 1/4" push in air line
- Lift cylinder includes magnetic piston and 4 mm sensor track for C-Track proximity sensors. Sensors not included.
- Requires cushioned or non-cushioned pallet stop. See page 28.
- Optional sensor mount for pallet. Sensor mounts are for standard 12 mm diameter proximity switch. See page 45 for sensor brackets.
- Optional guarding package

Pallet Sizes

		Length (mm)					
		160	240	320	400	480	640
Width (mm)	160	X	X				
	240	X	X	X		X	
	320		X	X		X	
	400				X	X	
	480		X	X	X	X	CF
	640					CF	CF

CF = Consult the Factory for availability and total load capacity



Optional Guarding Package



**RECOMMENDED ACCESSORY:
Pallet Guide Plate minimizes pallet twist**

Part Number 203747

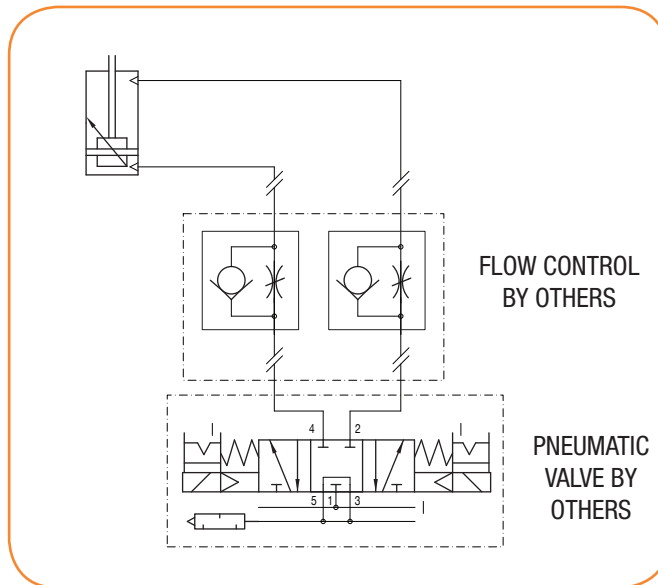
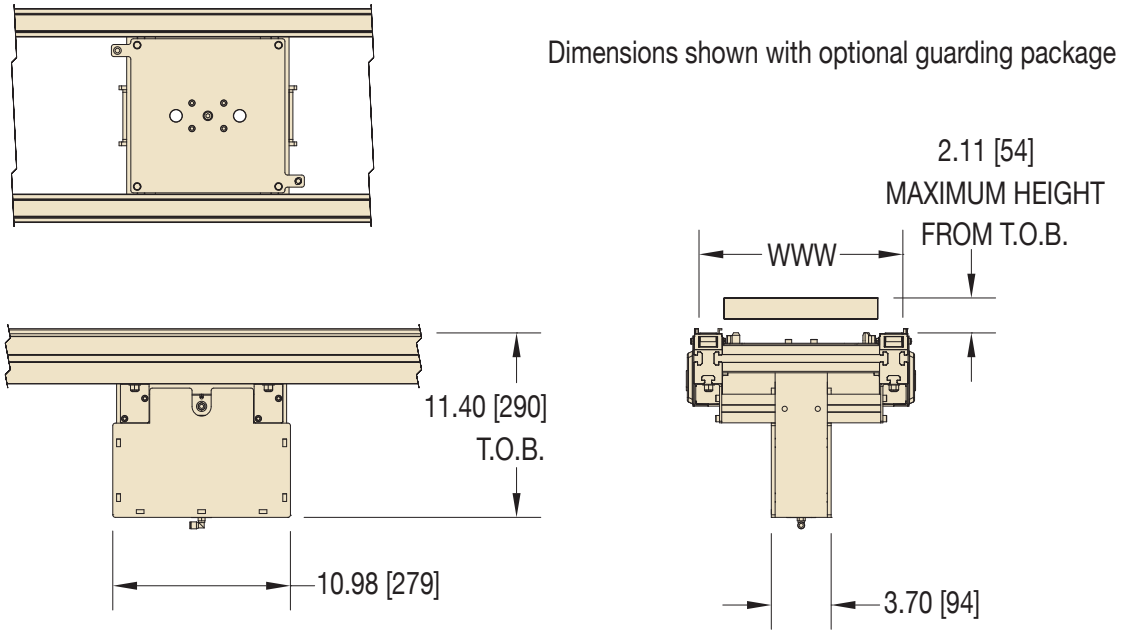

PNEUMATIC SCHEMATIC

2200 Series Precision Move: Lift and Locate

2 2 D S L M WWW - L L L C N G

- Guarding Included: N = No Guarding G = Guarding Included
- Pallet Sensor Option: N = No Sensor Bracket B = Bottom Sensor Bracket S = Side Sensor Bracket
- Stop Type: C = Cushioned F = Non-Cushioned N = None
- Pallet Length Reference: 160 = 160 mm 240 = 240 mm 320 = 320 mm 400 = 400 mm 480 = 480 mm
- Pallet Width Reference: 160 = 160 mm 240 = 240 mm 320 = 320 mm 400 = 400 mm 480 = 480 mm
- Documentation Language: M = US-English
- Conveyor Type: L = Lift and Locate

All combinations are valid except 160 mm width or length is not compatible with the bottom sensor bracket.

For detailed module spacing, see page 55. For pneumatic specifications, see page 54.

Note: Due to the wide variety of drive setups and applications, point of installation guarding is the responsibility of the end user.
Note: Dimensions = in (mm)

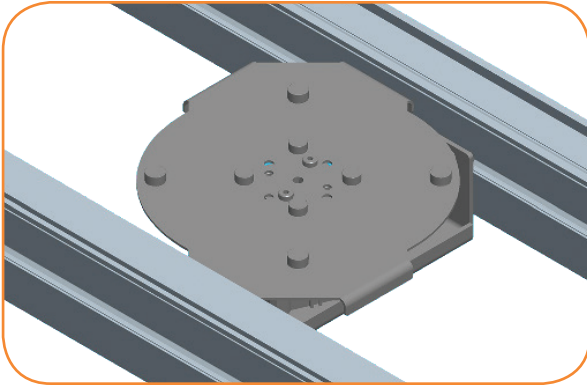

Specifications

- Lifts from center of conveyor
- Provides 200 lbs (91 kg) of lift capability at 90 psi
- Repeatability of $\pm .015''$
- Includes lift, mounting hardware and fittings for 1/4" push in air line
- Requires cushioned or non-cushioned pallet stop. See page 28.
- Optional sensor mount for pallet detection, sensor mounts are for standard 12 mm diameter proximity switch. See page 45 for sensor brackets.
- Lift cylinder includes magnetic piston and 4 mm sensor track for C-Track proximity sensors. Sensors not included.

		Pallet Sizes					
		Length (mm)					
		160	240	320	400	480	640
Width (mm)	160	X	X				
	240	X	X	X		X	
	320		X	X		X	
	400				X	X	
	480		X	X	X	X	CF
	640					CF	CF

CF = Consult the Factory for availability and total load capacity



RECOMMENDED ACCESSORY:
Pallet Guide Plate minimizes pallet twist

Part Number	203747
-------------	--------

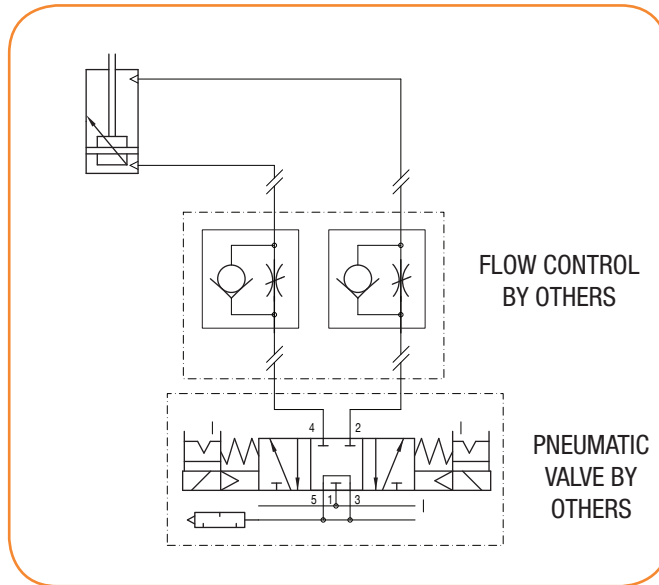
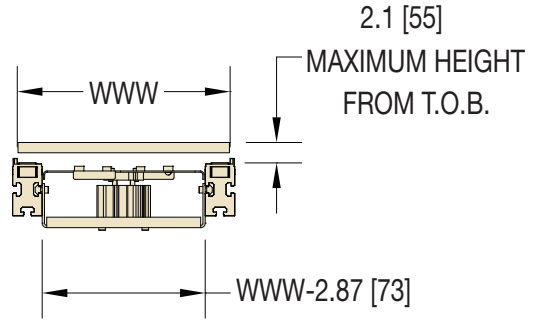
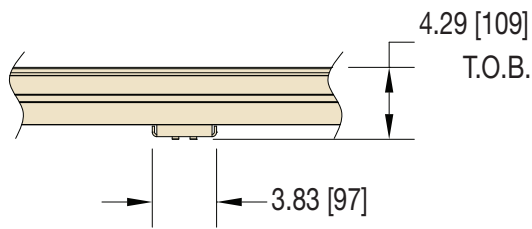
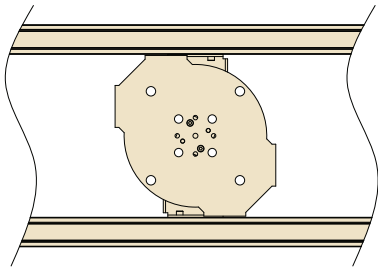

PNEUMATIC SCHEMATIC

2200 Series Precision Move: Lift and Locate

2 2 D S E M WWW - L L L C N G

- Guarding Included: N = No Guarding
- Pallet Sensor Option: N = No Sensor Bracket B = Bottom Sensor Bracket S = Side Sensor Bracket
- Stop Type: C = Cushioned F = Non-Cushioned N = None
- Pallet Length Reference: 160 = 160 mm 240 = 240 mm 320 = 320 mm 400 = 400 mm 480 = 480 mm
- Pallet Width Reference: 160 = 160 mm 240 = 240 mm 320 = 320 mm 400 = 400 mm 480 = 480 mm
- Documentation Language: M = US-English
- Conveyor Type: E = Low Profile Lift and Locate

All combinations are valid except 160 mm width or length is not compatible with the bottom sensor bracket.

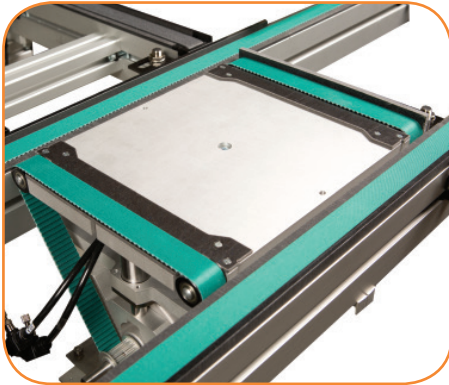
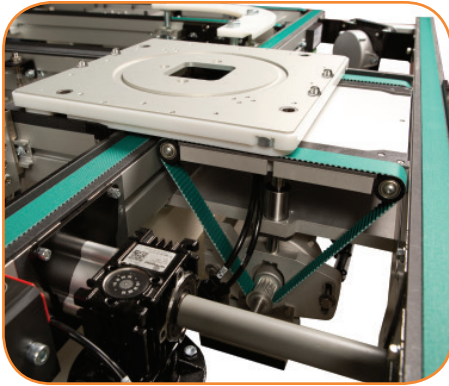

Specifications

- 3 position Lift and Transfer
 - Up position transfers pallet on/off the transverse conveyor
 - Middle position stops pallet on the main conveyor
 - Down position lowers the transfer and end stop allowing the pallet to pass over the lift and transfer
- Dual strand timing belt conveyors mounted to a pneumatic lift
- Changes product orientation at 90 degree corner
- 70 lbs (32 kg) load capacity
- Allows transfer to two directions if required
- Pallet transfers over conveyor high side. 0.25" (6 mm) change
 - No guide cutting required
- Includes (2) 24VDC Brushless drive motors and speed controls
 - 100 W output, Rated 4 Amps (0.17 Amps under no load) each
 - Belt speed: 20 – 67 ft./min. (6.09 – 20.4 m/min.)
 - Requires 24VDC power and single 24V PNP input to run
- Includes conveyor tie bracket
- End Stop - receiving, non-cushioned included
- Options:
 - Pallet sensor bracket sold separately. See page 45 for sensor brackets.
 - 3 Position Lift and Locate sensor bracket sold separately
 - Optional guarding package
 - Cushioned end stop

Pallet Sizes							
		Length (mm)					
		160	240	320	400	480	640
Width (mm)	160	X	X				
	240	X	X	X		X	
	320		X	X		X	
	400				X	X	
	480		X	X	X	X	CF
	640					CF	CF

CF = Consult the Factory for availability and total load capacity



Optional Guarding Package and Pallet Sensor

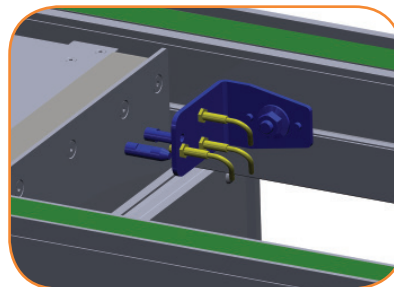

Optional Position Sensor Mount

Part Number 835-015

Requires 5 mm Diameter Proximity Sensors

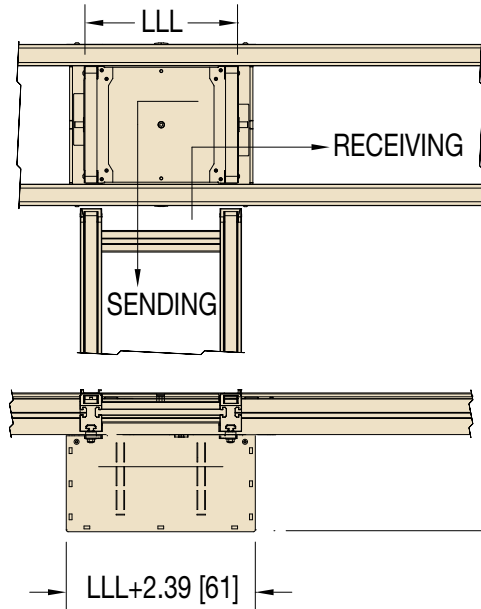

Dimensions shown with optional guarding package

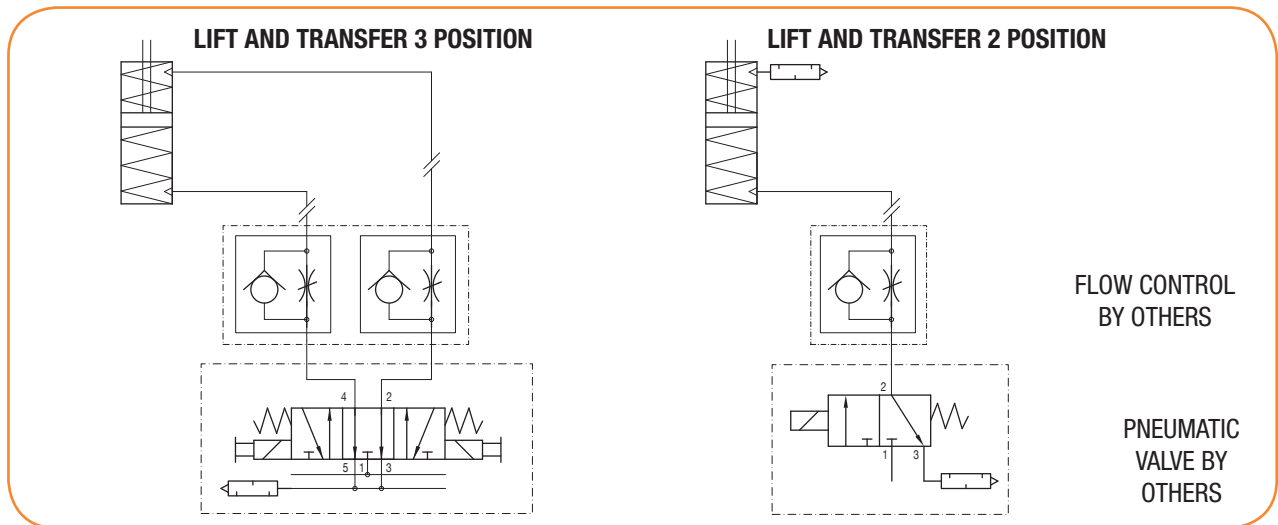
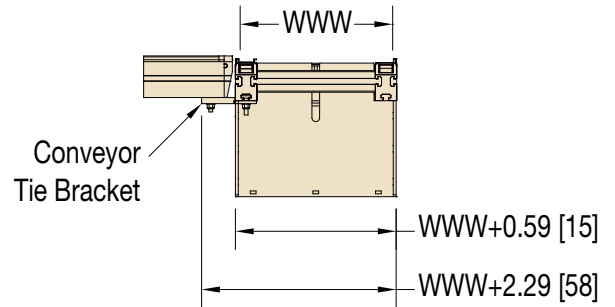

PNEUMATIC SCHEMATICS

2200 Series Precision Move: Lift and Transfer												
2	2	D	S	T	M	WWW	-	LLL	C	F	D	G
- Guarding Included: N = No Guarding G = Guarding Included - Direction: S = Sending R = Receiving - Flow Option: E = End Stop P = Pass Thru - Cushion Option: N = Non-Cushioned C = Cushioned - Pallet Length Reference: 160 = 160 mm 240 = 240 mm 320 = 320 mm 400 = 400 mm 480 = 480 mm - Pallet Width Reference: 160 = 160 mm 240 = 240 mm 320 = 320 mm 400 = 400 mm 480 = 480 mm - Documentation Language: M = US-English - Conveyor Type: T = Lift and Transfer												

All combinations are valid except 160 mm width or length is not compatible with the bottom sensor bracket.

For detailed module spacing, see page 55. For pneumatic specifications, see page 54.

Note: Due to the wide variety of drive setups and applications, point of installation guarding is the responsibility of the end user.
Note: Dimensions = in (mm)

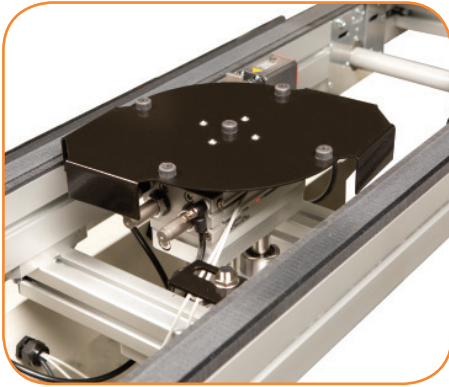
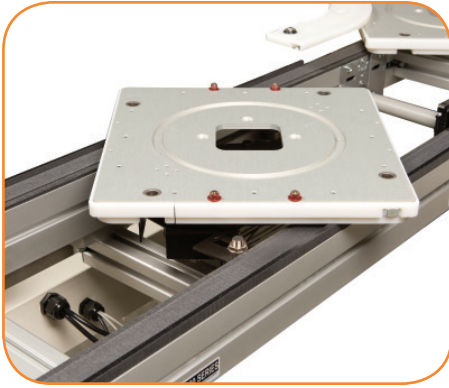

Specifications

- Pneumatic lift from center of conveyor
- Pneumatic rotation with adjustable positioning
- Includes break-away magnetic coupled rotation plate for product safety
- Rotation angle: 90 and 180 degrees
- Includes cushioned lift and turn strokes
- 200 lbs lift capacity
- Includes mechanism, mounting hardware and fittings for 1/4" push in air line
- Lift and Rotate cylinders include magnetic pistons and 4 mm sensor track for C-track proximity sensors. Sensors not included.
- Requires cushioned or non-cushioned pallet stop. See page 28.
- Optional sensor mount for pallet. Sensor mounts are for standard 12 mm diameter proximity switch. See page 45 for sensor brackets.
- Optional guarding package

Pallet Sizes

		Length (mm)					
		160	240	320	400	480	640
Width (mm)	160	X	X				
	240	X	X	X		X	
	320		X	X		X	
	400				X	X	
	480		X	X	X	X	CF
	640					CF	CF

CF = Consult the Factory for availability and total load capacity

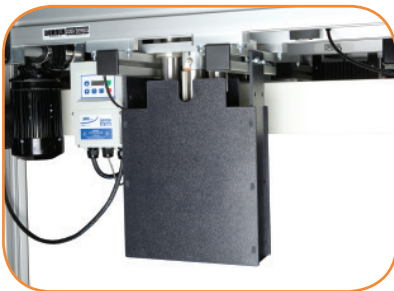

Optional Guarding Package



**STANDARD FEATURE:
Breakaway Top Plate**

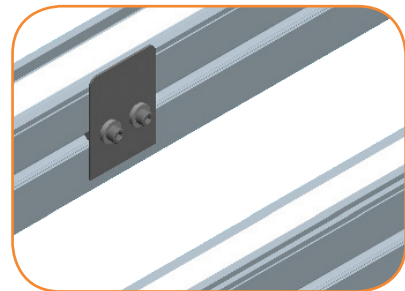

**RECOMMENDED ACCESSORY:
Pallet Guide Plate minimizes pallet twist**

Part Number 203747

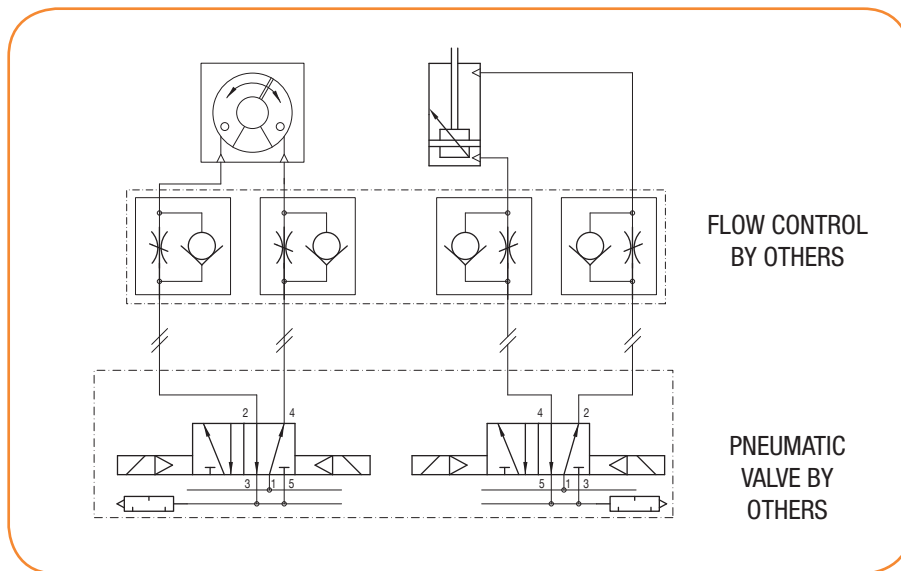
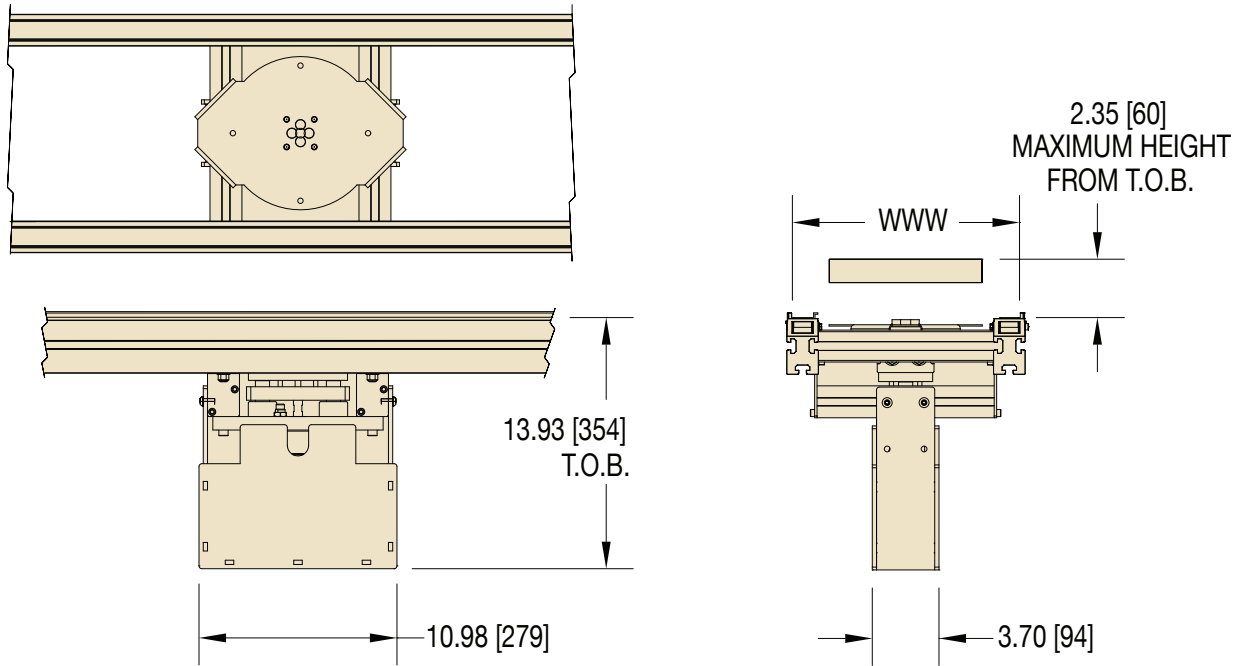

PNEUMATIC SCHEMATIC

2200 Series Precision Move: Lift and Rotate

2 2 D S R M WWW - L L L C N G

Guarding Included: N = No Guarding G = Guarding Included

Pallet Sensor Option: N = No Sensor Bracket B = Bottom Sensor Bracket S = Side Sensor Bracket

Stop Type: C = Cushioned F = Non-Cushioned N = None

Pallet Length Reference: 160 = 160 mm 240 = 240 mm 320 = 320 mm 400 = 400 mm 480 = 480 mm

Pallet Width Reference: 160 = 160 mm 240 = 240 mm 320 = 320 mm 400 = 400 mm 480 = 480 mm

Documentation Language: M = US-English

Conveyor Type: R = Lift and Rotate

Only square combinations are valid for 90 degree.

All combinations are valid except 160 mm width or length is not compatible with the bottom sensor bracket.

For detailed module spacing, see page 55. For pneumatic specifications, see page 54.

Note: Due to the wide variety of drive setups and applications, point of installation guarding is the responsibility of the end user.

Note: Dimensions = in (mm)

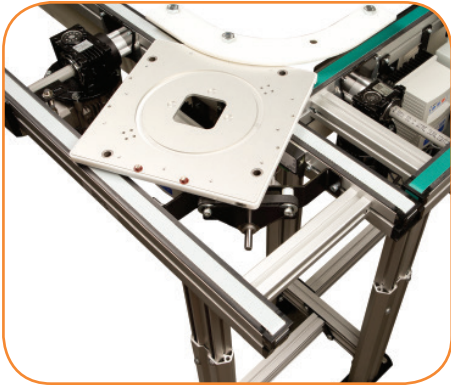

Specifications

- Requires pin tracking capability in pallet
- 1" (25 mm) of pallet space at side of pins required
- Up to 30 lbs (14 kg) load capacity
- Maintains product orientation around the corner
- Product accumulation in the corner is not recommended
- Inside guide is fixed mounted to transfer pallet around corner
- 24VDC mini-conveyors drive the pallet around the corner
- Mini-conveyor includes 24V Brushless DC drive motors with controls
 - 100 W output, Rated 4 Amps (0.17 Amps under no load)
 - Speed: 37 – 126 ft/min
 - Requires 24VDC power and single 24V PNP input to run
- Requires 3-leg support stand or conveyor tie brackets

Pallet Size Compatibility				
		Length (mm)		
		160	240	320
Width (mm)	160	X	X	
	240	X	X	X
	320		X	X

For large pallet sizes see heavy load corners.

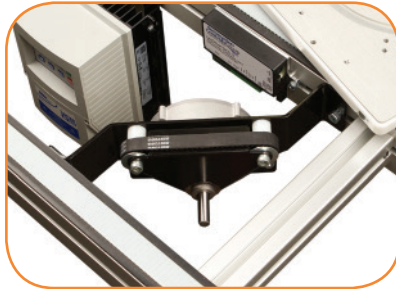

Mini Conveyor Drives Pallet around Corner

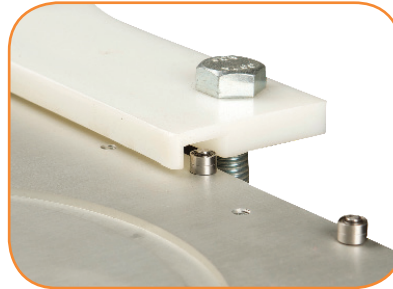

Pin Tracking

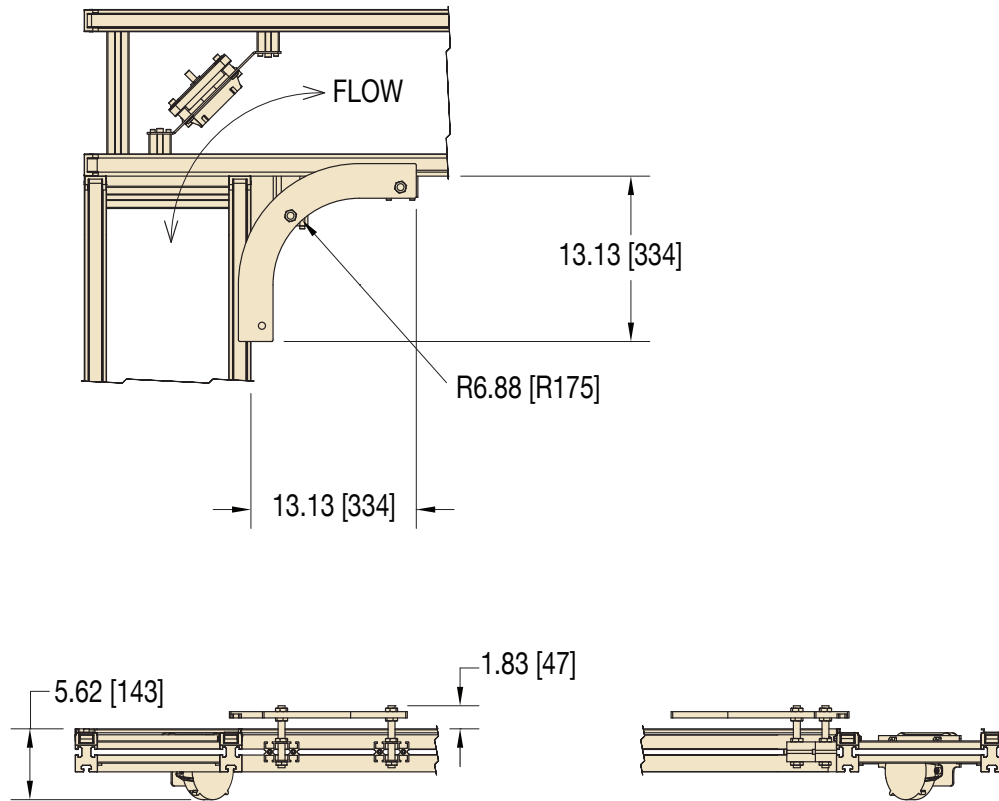

2200 Series Precision Move: 90 Degree Corner							
2	2	D	S	T	M	WWW	D
				Direction: L = Right R = Right			
				Pallet Width Reference: 160 = 160 mm 240 = 240 mm 320 = 320 mm			
				Documentation Language: M = US-English			
				Conveyor Type: T = Fixed Corner Turn			

For detailed module spacing, see page 55. For pneumatic specifications, see page 54.

Note: Due to the wide variety of drive setups and applications, point of installation guarding is the responsibility of the end user.
Note: Dimensions = in (mm)

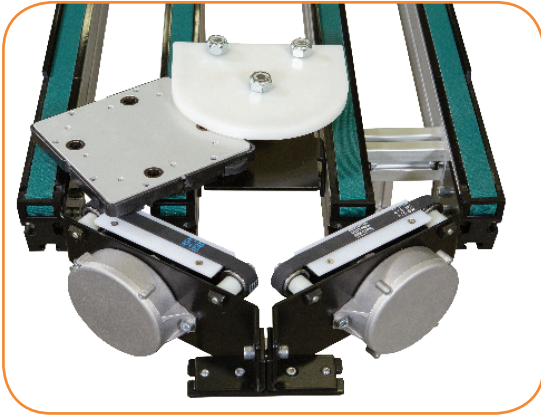

Specifications

- Requires pin tracking capability in pallet
- 1" (25 mm) of pallet space at side of pins required
- Up to 30 lbs (14 kg) load capacity
- Maintains product orientation around the corner
- Product accumulation in the corner is not recommended
- Inside guide is fixed mounted to transfer pallet around corner
- Two 24VDC mini-conveyors drive the pallet around the corner
- Mini-conveyors include two 24V Brushless DC drive motors with controls
 - 100 W output, rated 4 Amps (0.17 Amps under no load)
 - Speed: 37 – 126 ft/min
 - Requires 24VDC power and single 24V PNP input to run
- Includes support stand and hardware

Pallet Size Compatibility			
	Length (mm)		
	160	240	320
Width (mm)			
160	X	X	
240	X	X	X
320		X	X

For large pallet sizes see heavy load corners.

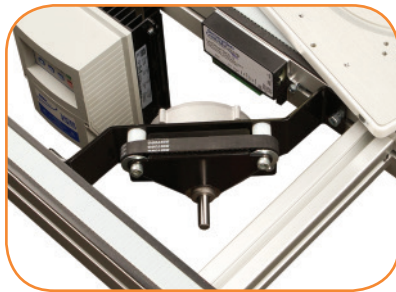

**Mini Conveyor Drives
Pallet around Corner**

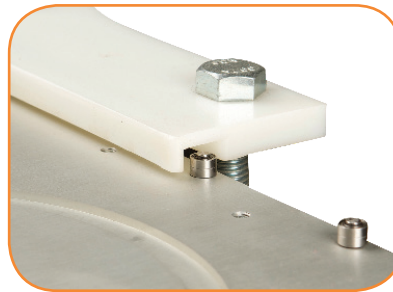

Pin Tracking

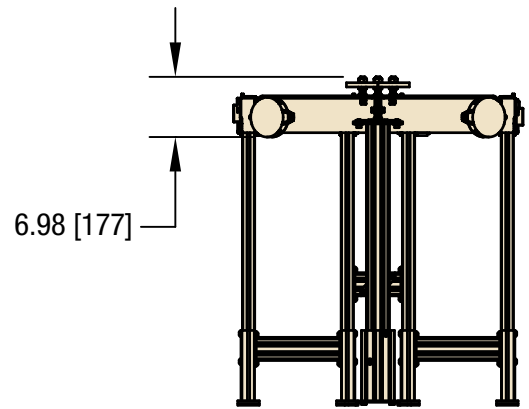
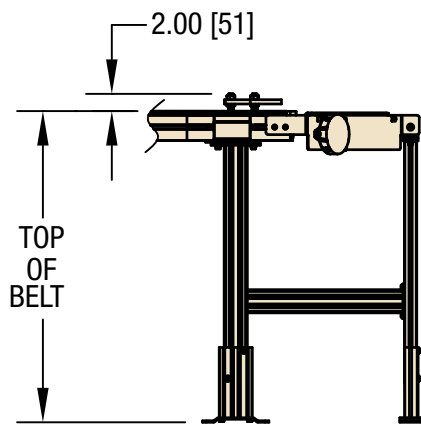
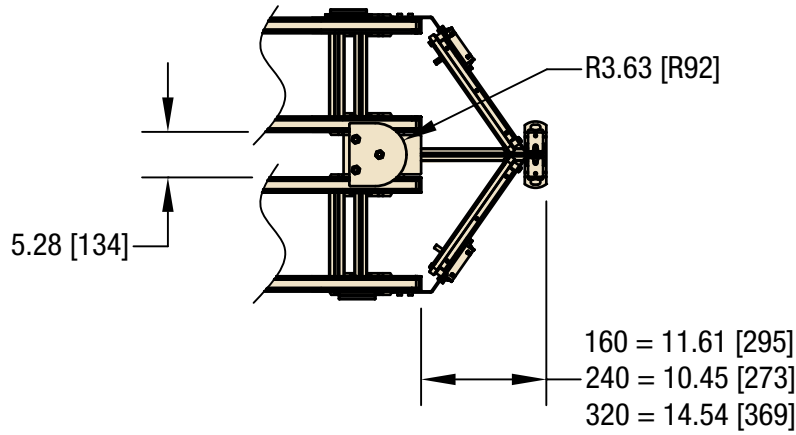

2200 Series Precision Move: 180 Degree Corner												
2	2	D	S	U	M	WWW	-	AAA	LH	UH	F	D
- Direction: L = Left R = Right - Footing: F = Fixed - Tallest Height to TOB (in inches) - Lowest Height to TOB (in inches) - Angle Reference: 180 = 180 Degree - Conveyor Width Reference: 160 = 160 mm 240 = 240 mm 320 = 320 mm - Documentation Language: M = US-English - Conveyor Type: U = 180 Degree Corner												

All combinations are valid except 160 mm width or length is not compatible with the bottom sensor bracket.

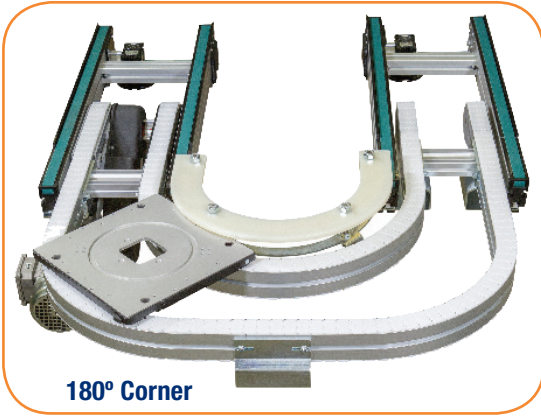

180° Corner

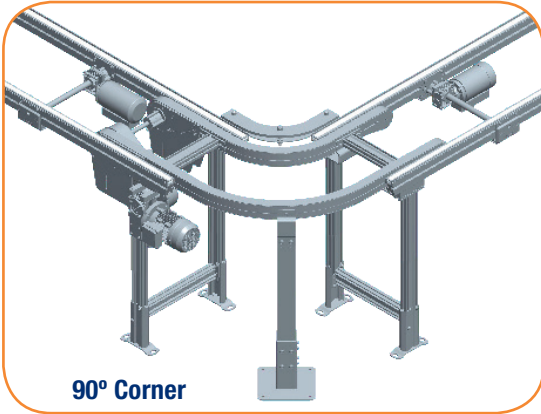

90° Corner

Specifications

- Requires pin tracking capability in pallet
- 1" (25 mm) of pallet space at side of pins required
- 150 lbs (68 kg) load capacity
- Maintains product orientation around the corner
- Product accumulation in the corner is allowed (75 lbs (34 kg) maximum)
- Inside guide is fixed mounted to transfer pallet around corner
- Includes all brackets and hardware to mount corner conveyor to the main lines. Includes support stands.
- Belt Speed is matched to main lines
- Separate gearmotor and drive is required for the corner conveyor.

Pallet Size Compatibility

		Length (mm)				
		240	320	400	480	640
Width (mm)	240	X	X		X	
	320		X		X	
	400			X	X	
	480	X	X	X	X	CF
	640				CF	CF

CF = Consult the Factory for availability and total load capacity

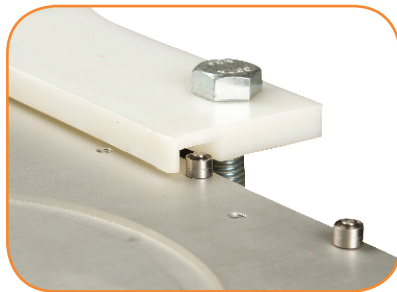

Pin Tracking

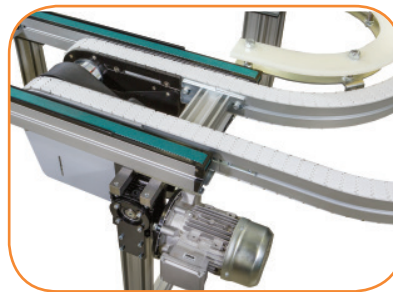

Common Drive

2200 Series Precision Move: Heavy Load 90 and 180 Degree Corner

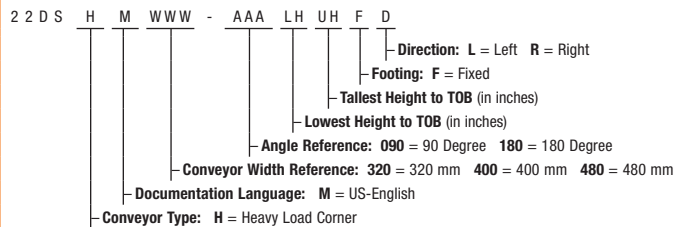

All combinations are valid except 160 mm width or length is not compatible with the bottom sensor bracket.

For detailed module spacing, see page 55. For pneumatic specifications, see page 54.

90 Degree
Corner

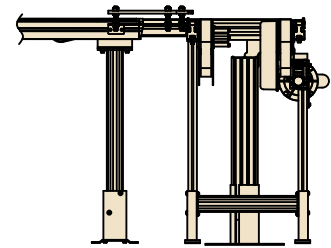
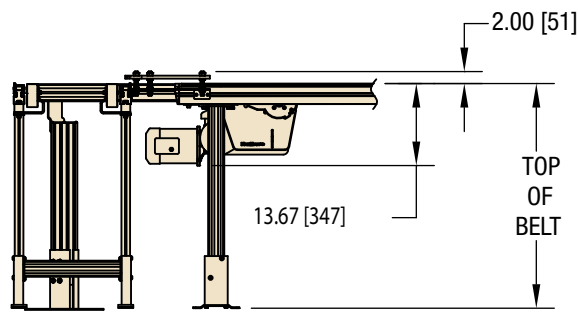
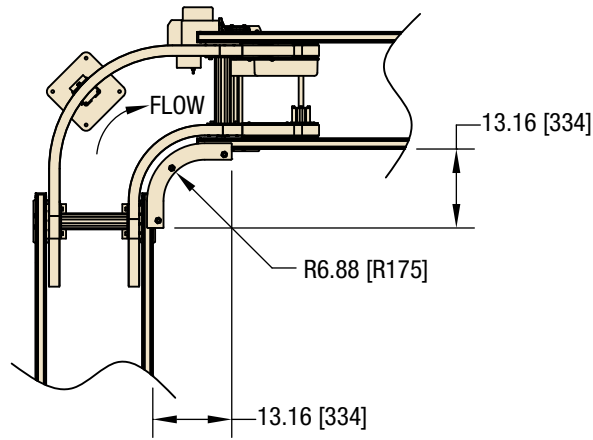

180 Degree
Corner

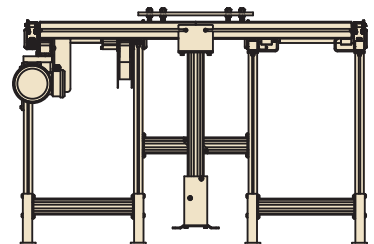
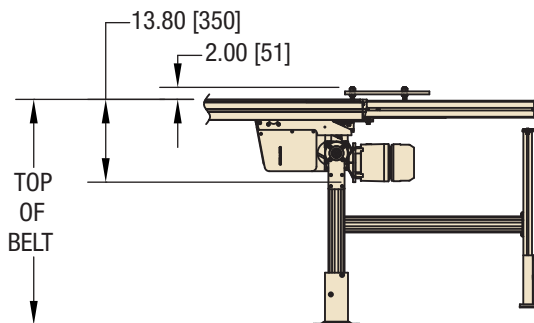
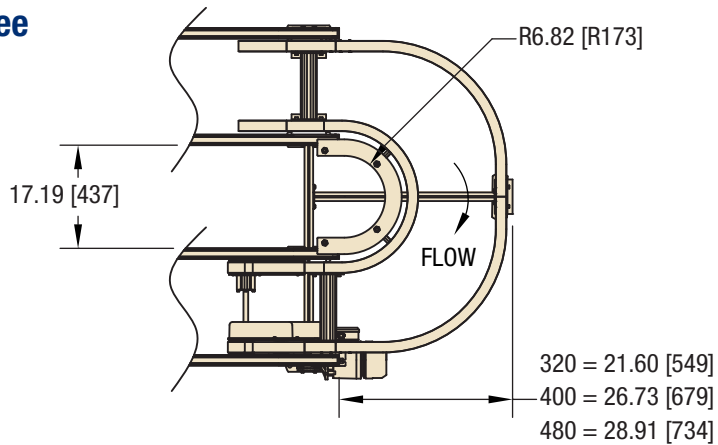

Note: Due to the wide variety of drive setups and applications, point of installation guarding is the responsibility of the end user.
Note: Dimensions = in (mm)

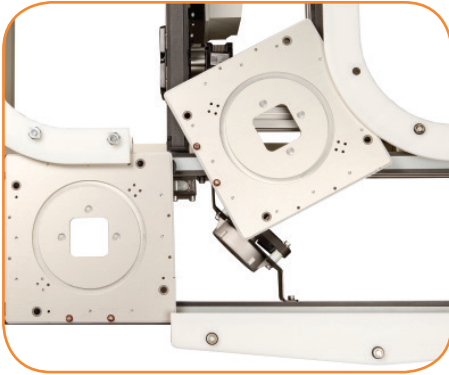

Specifications

- Requires pin tracking capability in pallet
- 1" (25 mm) of pallet space at side of pins required
- 30 lbs (14 kg) load capacity (70 lbs (32 kg) available - consult factory)
- Maintains product orientation
- Inside guide is raised with pneumatic cylinders to clear flow through
- Straight guide with pneumatic cylinder is mounted across perpendicular conveyor to guide pallets straight through the merge area
- Includes sensor mount track on guide cylinder for C-track 4 mm proximity sensors
- 160 mm wide units have no added mini-conveyor
- 240 mm and 320 mm have a 24VDC mini-conveyor added to drive the pallet around the corner
- Mini-conveyor includes 24V Brushless DC drive motor with controls
 - 100 W output, rated 4 Amps (0.17 Amps under no load)
 - Belt speed: 37 – 126 ft/min
 - Requires 24VDC power and single 24V PNP input to run
- Requires pallet stops for traffic control. See page 28.
- Includes low side guide and tail part
- Requires support stand or conveyor tie bracket to connect conveyors. See pages 43-44.

Pallet Size Compatibility

		Length (mm)		
		160	240	320
Width (mm)	160	X	X	
	240	X	X	X
	320		X	X

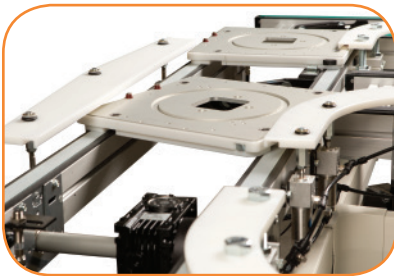

**Pneumatic Activated
Transfer Guides**

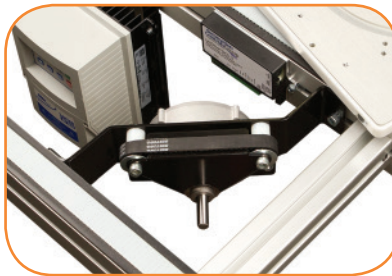

**Mini Conveyor Drives
Pallet around Corner**

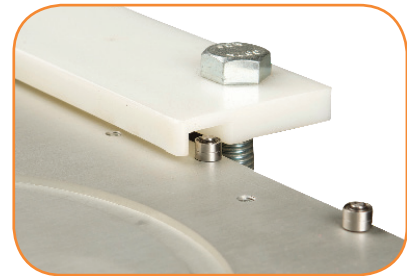

Pin Tracking

Note: Due to the wide variety of drive setups and applications, point of installation guarding is the responsibility of the end user.
Note: Dimensions = in (mm)

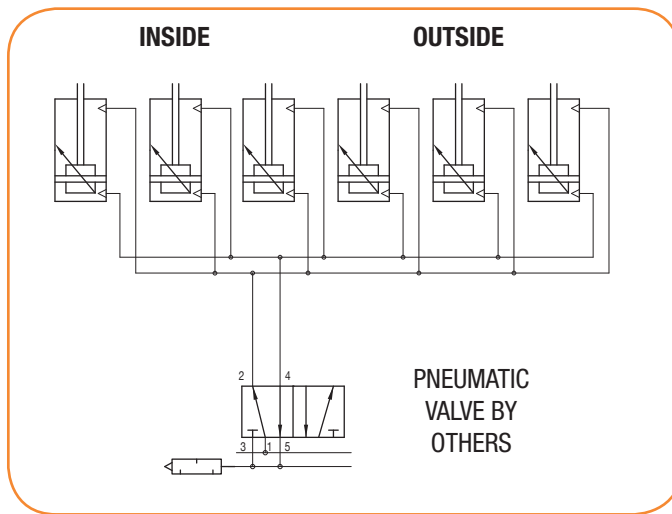
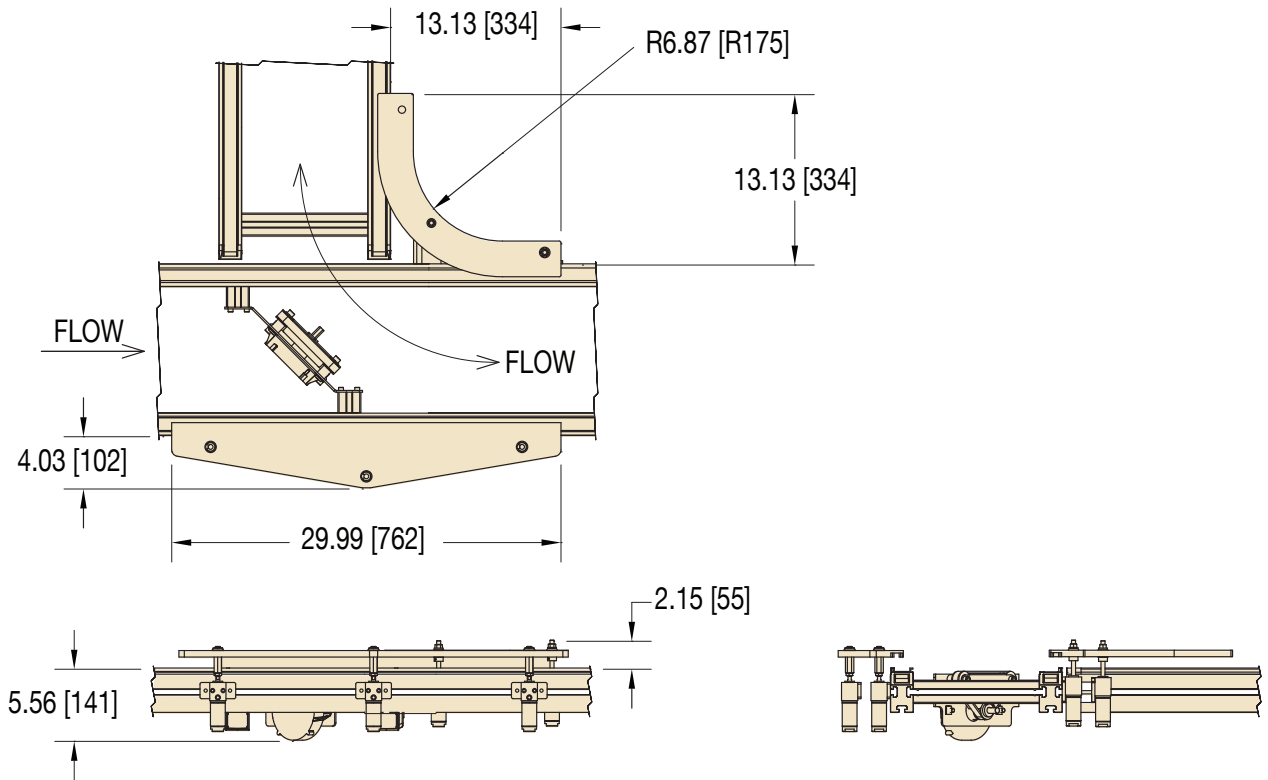

PNEUMATIC SCHEMATIC

2200 Series Precision Move: 90 Degree Corner and Merge

2	2	D	S	M	M	WWW	-	N	D
Direction: L = Right R = Right Pallet Sensor Option: N = No Sensor Bracket B = Bottom Sensor Bracket S = Side Sensor Bracket Pallet Width Reference: 160 = 160 mm 240 = 240 mm 320 = 320 mm Documentation Language: M = US-English Conveyor Type: M = Merge Corner									

For pneumatic specifications, see page 54.

Note: Due to the wide variety of drive setups and applications, point of installation guarding is the responsibility of the end user.
 Note: Dimensions = in (mm)

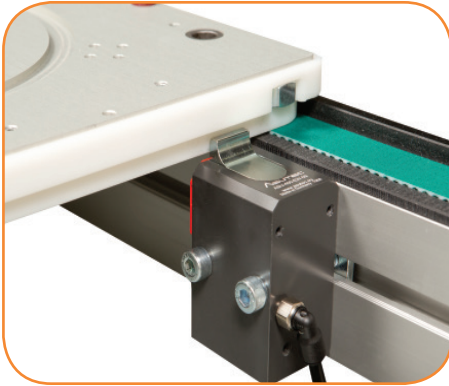

Pallet Stop – Non-cushioned

Non-cushioned pallet stop for traffic control. Stops one or more pallets at the specified location on the conveyor. Air pressure disengages the stop allowing pallets to pass until the pressure is released. A spring return re-engages the pallet stop.

Specifications

- Maximum Load: 150 lbs (68 kg) accumulated
- Pneumatically activated, spring return
- Not suitable for reversing application
- Mounts on the inside of the conveyor rail
- Airline can be mounted on the front or back of the stop
- Includes: stop, mounting hardware, and fittings for ¼" push in air line
- Optional vertical or side mounted sensor bracket. See page 45.

Part Number 205758

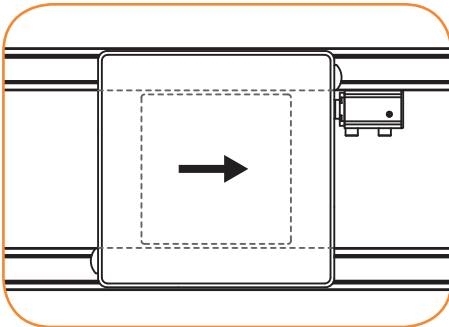

Stop Located After Pallet

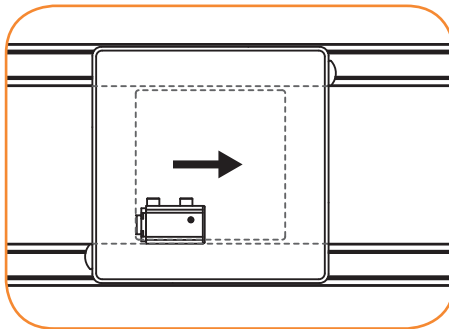

Stop Located Inside Pallet

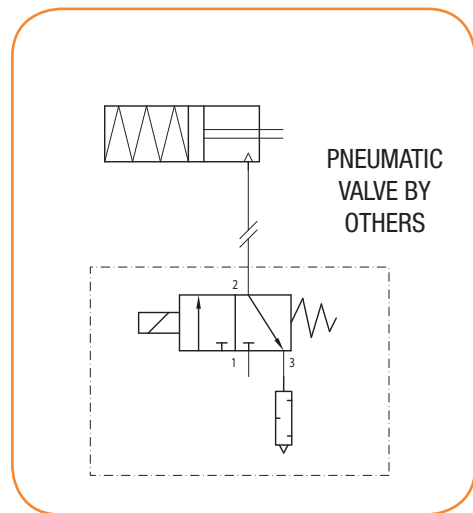
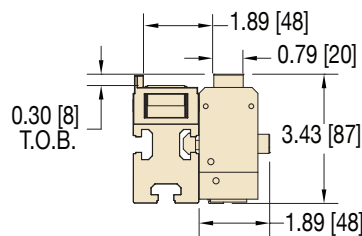
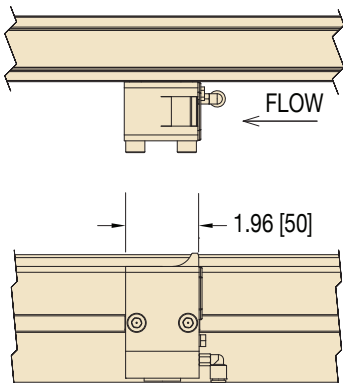
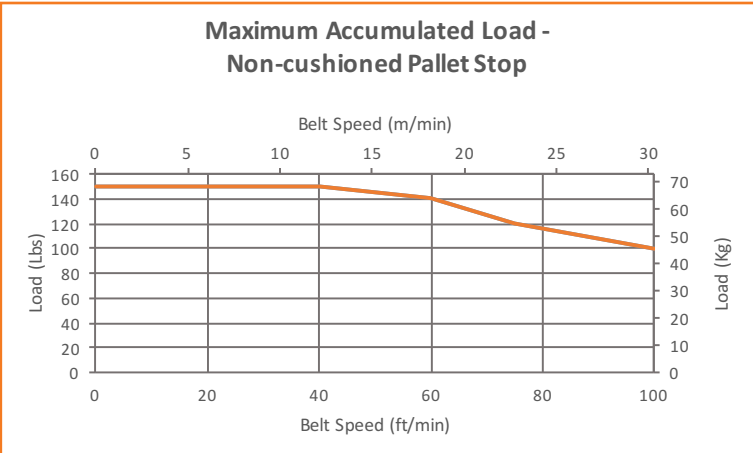

PNEUMATIC SCHEMATIC

For pneumatic specifications, see page 54.

Note: Due to the wide variety of drive setups and applications, point of installation guarding is the responsibility of the end user.
Note: Dimensions = in (mm)

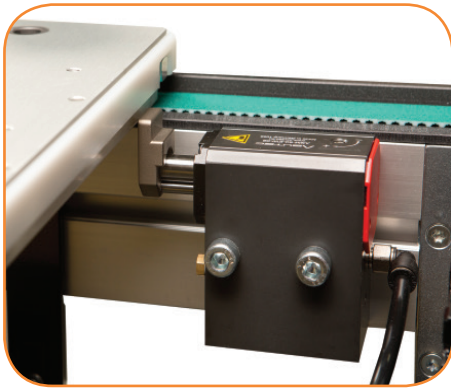

Pallet Stop – Cushioned

Cushioned pallet stop for traffic control. Stops one or more pallets at the specified location on the conveyor. Cushioned deceleration of the first pallet into the stopped location guarding against vibration of sensitive payloads. Accumulated pallets are not cushioned. Air pressure disengages the stop allowing pallets to pass until the pressure is released. A spring return re-engages the pallet stop and resets the cushion.

Specifications

- Maximum Load: 150 lbs (68 kg) accumulated
- Pneumatically activated, spring return
- Stops the pallet on the leading or trailing edge
- Not suitable for reversing application
- Mounts on the inside of the conveyor rail
- Airline can be mounted on the front or back of the stop
- Includes: stop, mounting hardware, and fittings for 1/4" push in air line
- Optional vertical or side mounted sensor bracket. See page 45.

Part Number 205756

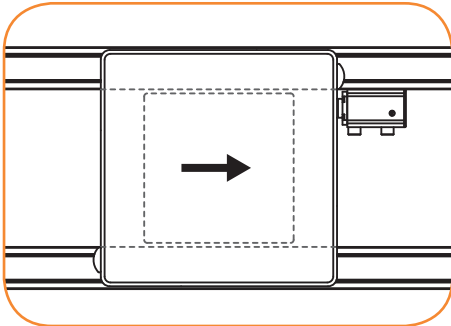

Stop Located After Pallet

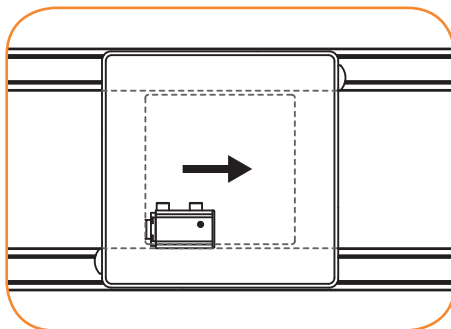

Stop Located Inside Pallet

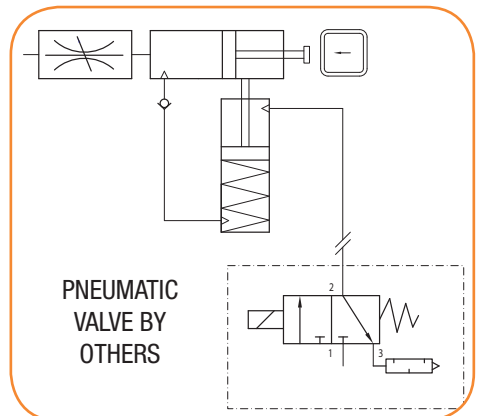
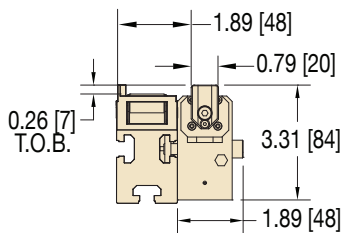
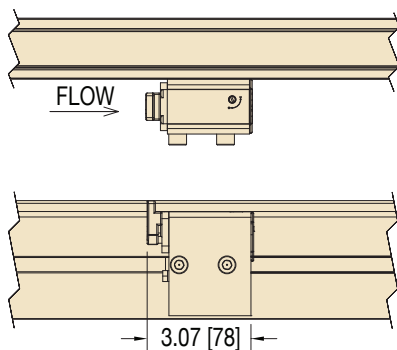
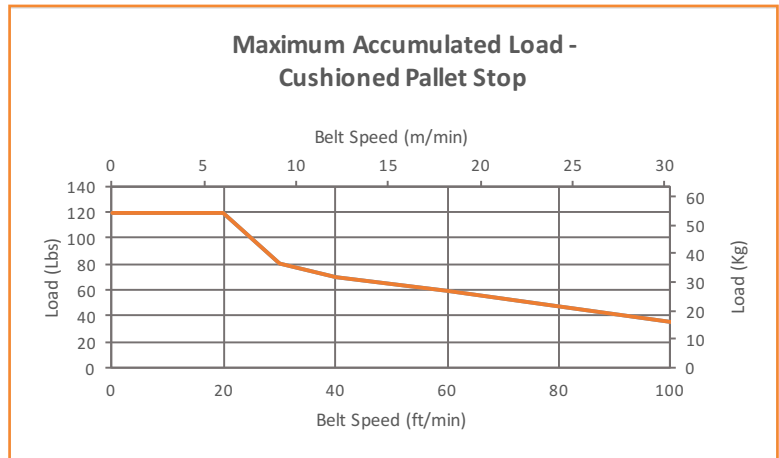

PNEUMATIC SCHEMATIC

For pneumatic specifications, see page 54.

Note: Due to the wide variety of drive setups and applications, point of installation guarding is the responsibility of the end user.

Note: Dimensions = in (mm)

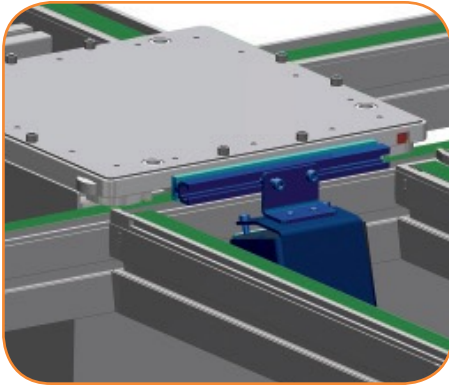

Pass Through Stop – Non-cushioned

The Non-cushioned Pass-Through Stop is used in a transverse line with lift and transfer modules that connect two or more main lines. When the stop is in the extended position, it stops the pallet. When the stop is retracted, it allows pallets to pass through.

Specifications

- Maximum Load: 70 lbs (32 kg)
- Pneumatic activated extend and retract
- Mounts to the outside rail on the main line conveyor
- Includes: stop, mounting hardware, and fittings for ¼" push in air

Part Number	206645-WWW
-------------	------------

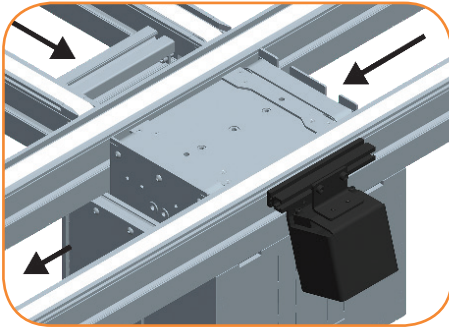

Pass Through - Receiving

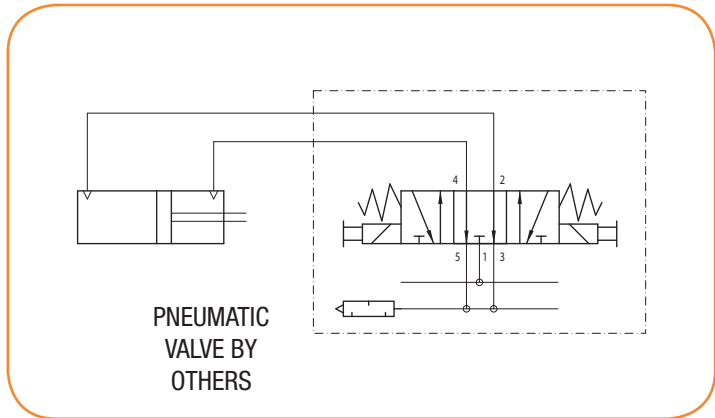

PNEUMATIC SCHEMATIC

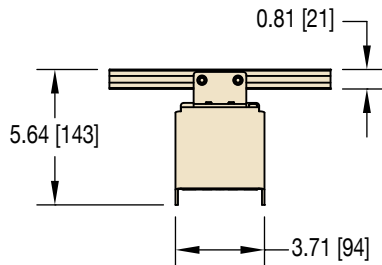
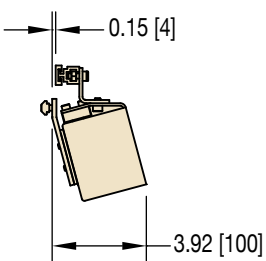
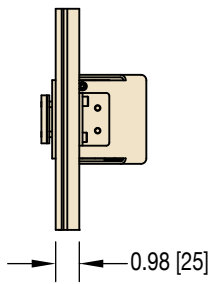

For pneumatic specifications, see page 54.

Note: Due to the wide variety of drive setups and applications, point of installation guarding is the responsibility of the end user.
Note: Dimensions = in (mm)

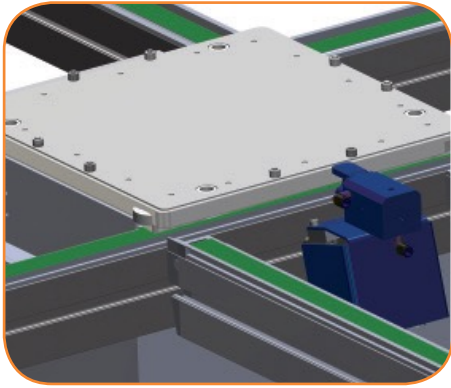

Pass Through Stop – Cushioned

The Cushioned Pass-Through Stop is used in a transverse line with lift and transfer modules that connect two or more main lines. Cushioned deceleration of the pallet into the stopped location guarding against vibration of sensitive payloads. When the stop is in the extended position, it stops the pallet. When the stop is retracted, it allows the pallet to pass through.

Specifications

- Maximum Load: 70 lbs (32 kg)
- Cushioned Stop for sensitive payloads
- Pneumatic actuated extend and retract
- Pneumatic cushion return
- Mounts to the outside rail of the main line conveyor
- Includes: stop, mounting hardware, and fittings for 1/4" push in air

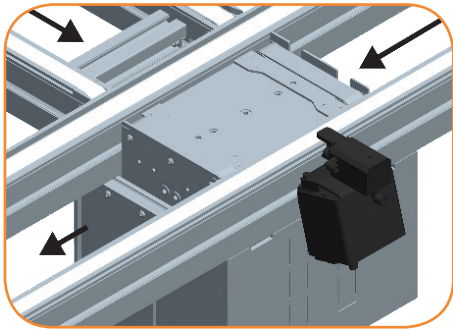

Pass Through – Receiving

Part Number	204750
-------------	--------

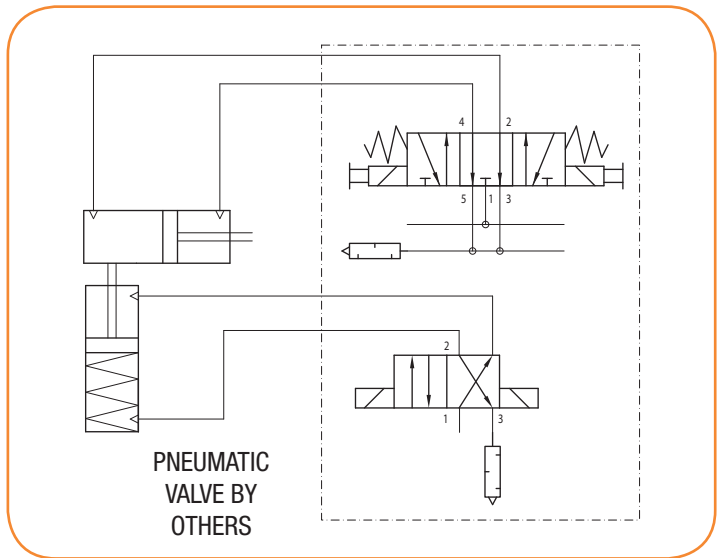

PNEUMATIC SCHEMATIC

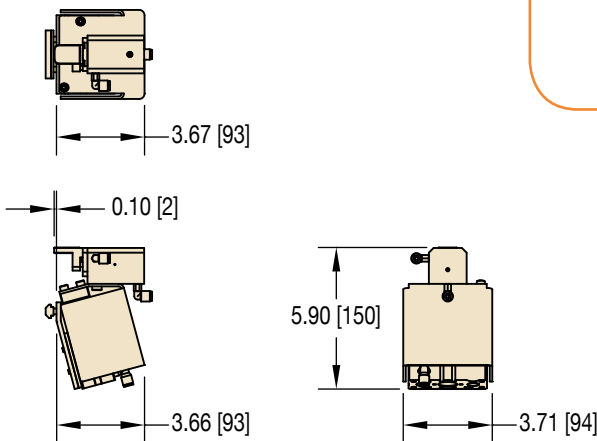

For pneumatic specifications, see page 54.

Note: Due to the wide variety of drive setups and applications, point of installation guarding is the responsibility of the end user.

Note: Dimensions = in (mm)

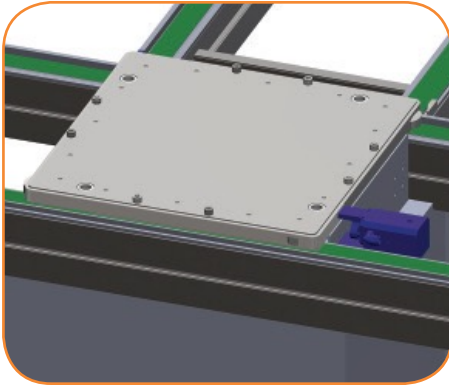

End Stop – Sending – Cushioned

The Cushioned End Stop decelerates the pallet into the lift and transfer station when sending to a transverse conveyor.

Specifications

- Maximum Load: 70 lbs (32 kg)
- Cushioned Stop for sensitive payloads
- Momentarily energized to reset the cushion
- Includes: stop, mounting hardware, and fittings for ¼" push in air
- Mounted to the lift and transfer

Part Number	204747
-------------	--------

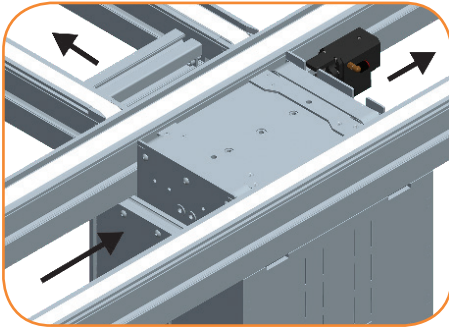

End Stop – Sending

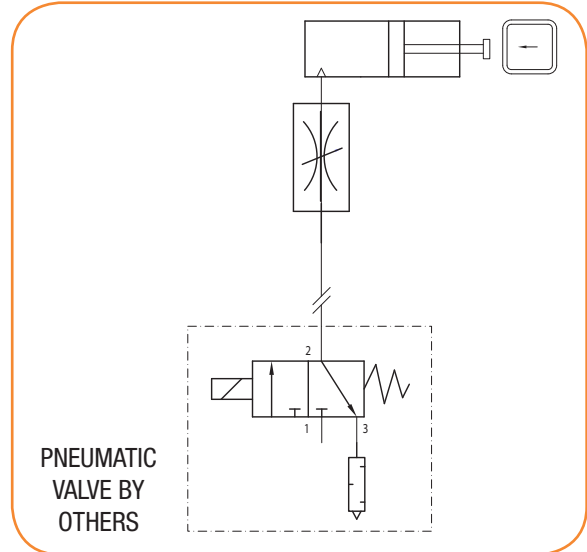
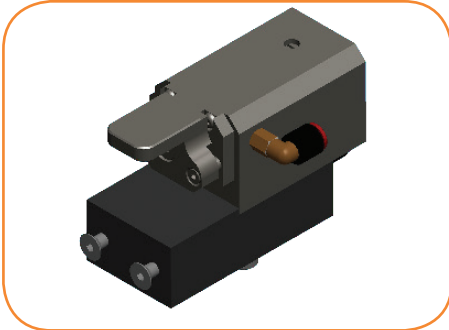

PNEUMATIC SCHEMATIC

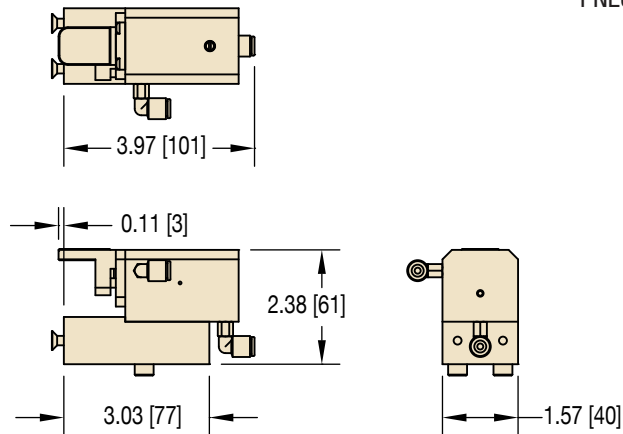

For pneumatic specifications, see page 54.

Note: Due to the wide variety of drive setups and applications, point of installation guarding is the responsibility of the end user.
Note: Dimensions = in (mm)

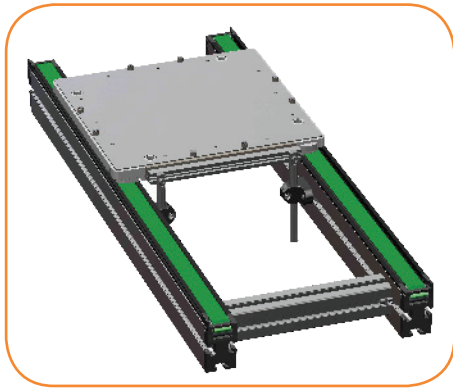

End Stop – Receiving – Non-cushioned

Non-cushioned Fixed End Stop attached to main conveyor line outside of a Lift and Transfer unit. Positions pallet on the Lift and Transfer unit prior to the pallet being lowered onto the main conveyor (receiving) line.

Specifications

- Maximum Load: 120 lbs (54 kg)
- Mounts to the outside rail of the main line conveyor
- Includes all mounting hardware
- No pneumatics required

Part Number	206646-WWW
	Width 160, 240, 320, 400, 480

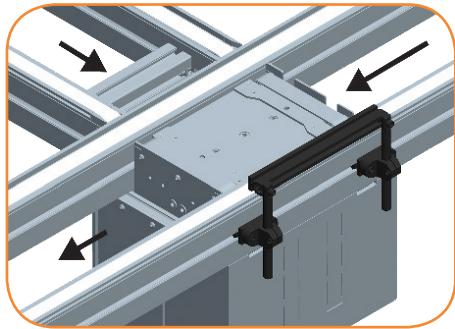

End Stop – Receiving

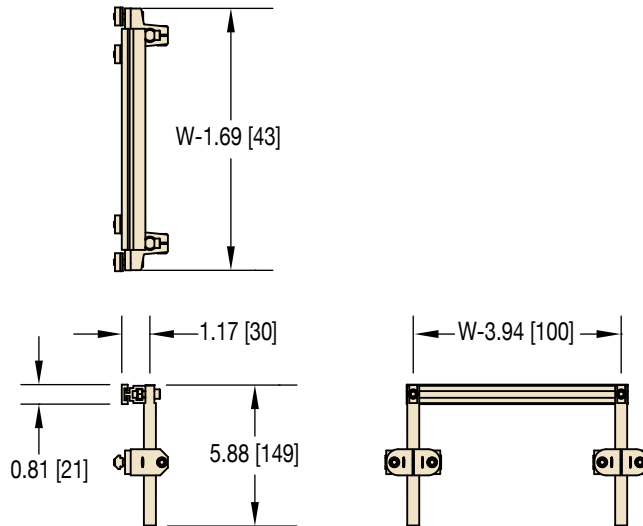

For pneumatic specifications, see page 54.

Note: Due to the wide variety of drive setups and applications, point of installation guarding is the responsibility of the end user.
Note: Dimensions = in (mm)

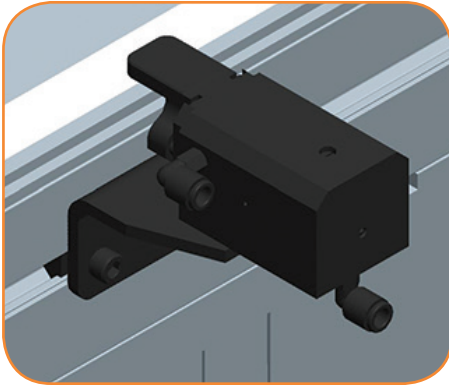

End Stop – Receiving – Cushioned

The Cushioned End Stop decelerates the pallet into the Lift and Transfer station when receiving from a transverse conveyor.

Specifications

- Maximum Load: 70 lbs (32 kg)
- Cushioned Stop for sensitive payloads
- Momentarily energized to reset the cushion
- Includes: stop, mounting hardware, and fittings for ¼" push in air
- Mounts to the outside rail of the main line conveyor

Part Number	204757
-------------	--------

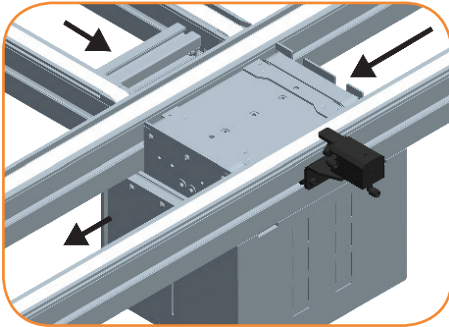

End Stop – Receiving – Cushioned

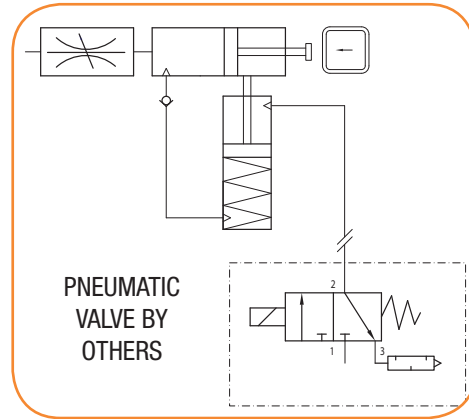

PNEUMATIC SCHEMATIC

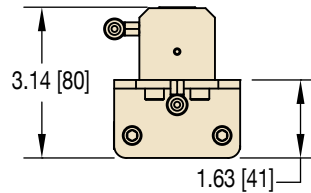
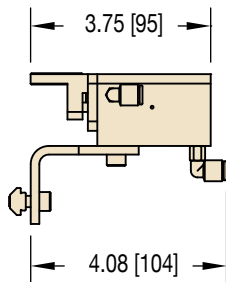
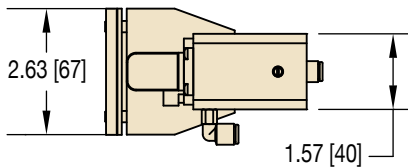

For pneumatic specifications, see page 54.

Note: Due to the wide variety of drive setups and applications, point of installation guarding is the responsibility of the end user.
Note: Dimensions = in (mm)

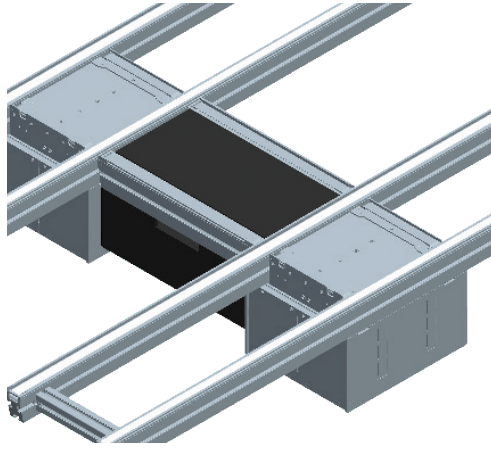

Tandem Lift and Transfer

Tandem Lift and Transfer unit sends and receives pallet from parallel conveyor lines. The Lift and Transfer units are slave driven from the transverse conveyor.

- 3 position Lift and Transfer
 - Up position transfers pallet on/off the transverse conveyor
 - Middle position stops pallet on the sending conveyor
 - Down position lowers the transfer and end stop allowing the pallet to pass over the lift and transfer
- Changes product orientation at 90 degree corner
- 70 lbs (32 kg) load capacity
- Allows transfer in two directions if required
- Pallet transfers over high side 0.25" (6 mm) change
 - No guide cutting required
- Lift and transfers slave driven by transverse conveyor
- Includes Conveyor tie brackets
- Non-cushioned end stop included
- Options:
 - Pallet sensor bracket sold separately. See page 45 for sensor brackets.
 - 3 position Lift and Locate sensor bracket sold separately
 - Optional guarding package
 - Cushioned end stop
- Available for standard and custom pallet sizes

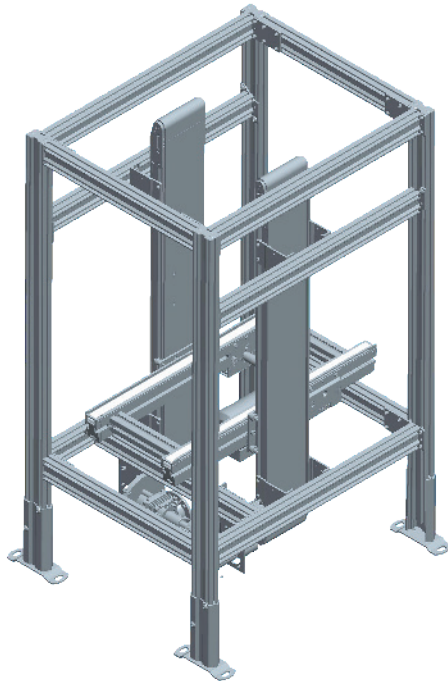

Vertical Transfer Unit (Elevator)

Vertical Transfer Units raise or lower a pallet between two different levels allowing for over/under layouts or transferring pallets over aisles.

- Includes Precision Move conveyor to shuttle pallets in and out of the Vertical Transfer Unit
- Transfers standard and custom pallet sizes
- Up to 200 lbs (91 kg) lift capacity
- Minimum Height TOB: 12" (305 mm)
- Maximum height TOB 120" (3050 mm)
- Transfer one or more pallet(s) per cycle
- AC VFD rated gearmotor driven lift and shuttle
- Includes Lexan guarding
- Includes proximity sensor brackets for pallet and lift position detection
- Available as a complete package including automation controls

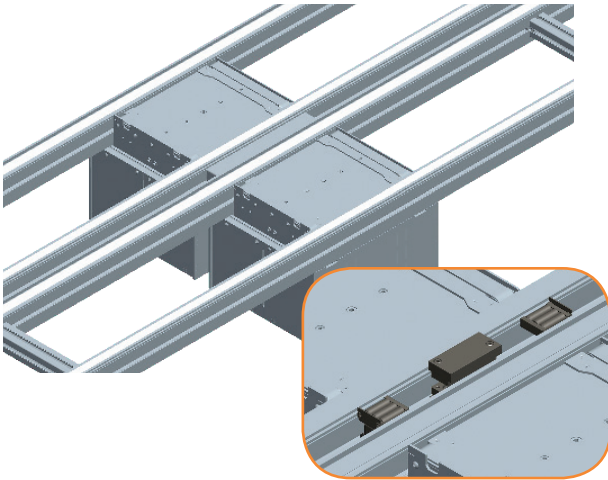

Close Transfer Rollers

Pallet transfer roller assembly for closely spaced parallel conveyors eliminating the need for a separate transverse conveyor. The transfer rollers are located between lift and transfer stations to prevent the pallet from stopping between the lift and transfers.

- Available in 45 mm increments
- Maximum spacing between parallel conveyor using transfer rollers in lieu of a transverse conveyor
 - 160 – 45 mm
 - 240 – 90 mm
 - 320 – 135 mm
 - 400 – 180 mm
 - 480 – 225 mm

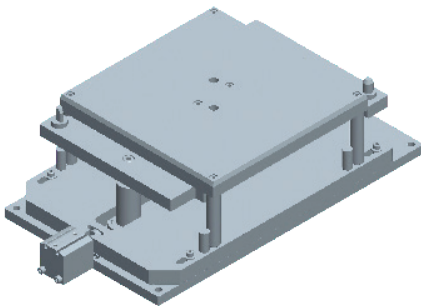

Heavy Duty Lift and Locate

Heavy duty Lift and Locate is used for operations that require large downward force such as pressing or riveting processes. The anvil lifts and mechanically locks in place isolating pressing forces from the conveyor line.

- Withstands up to 5000 lbs (2,268 kg) of downward force
- Available for standard pallet sizes
- Pneumatically operated anvil and locking mechanism
- Isolates pressing forces from the conveyor
- Requires floor mount support by others

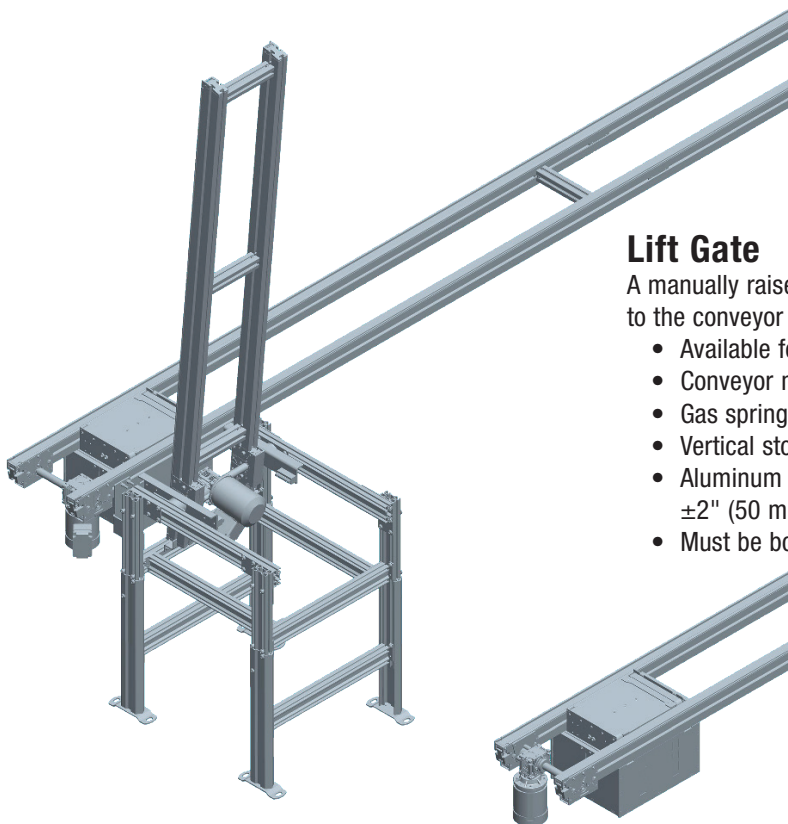

Lift Gate

A manually raised and lowered conveyor section to allow access to the conveyor line.

- Available for standard and custom pallet sizes
- Conveyor motor used as the counter weight for easier lifting
- Gas spring controlled pivot mechanism
- Vertical stop position
- Aluminum support structure with T-slot construction and $\pm 2"$ (50 mm) adjustability
- Must be bolted to the floor

Timing Belt Guide

Part Number Reference	Belt Specifications	Tooth Pitch	Thickness	Material	Top Surface	Color	Temperature Range	Maximum Tensile Force	Coefficient of Friction	Width
1D	Low Friction	5 mm	2.2 mm	Polyamide Fabric Top, Urethane base material, Steel cords	Fabric	Green	-22 to 176° F (-30 to 80° C)	94 lbs (420 N)	Very low	25 mm
2D	Medium Friction	5 mm	2.2 mm	Urethane Top, Urethane base material, Steel cords	Smooth	Off White	-22 to 176° F (-30 to 80° C)	94 lbs (420 N)	Medium	25 mm
6D	Anti-static Low Friction*	5 mm	2.2 mm	Anti-static Fabric Top, Urethane base material, Steel cords	Fabric	Black	-22 to 176° F (-30 to 80° C)	94 lbs (420 N)	Very low	25 mm

*Note: Anti-static belts are in full compliance with ISO standard 9563.

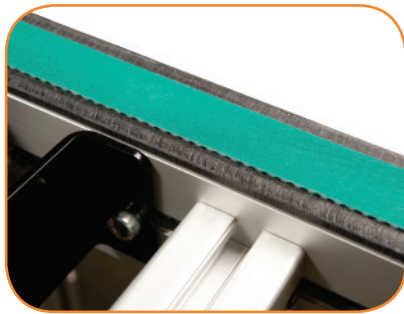

Low Friction

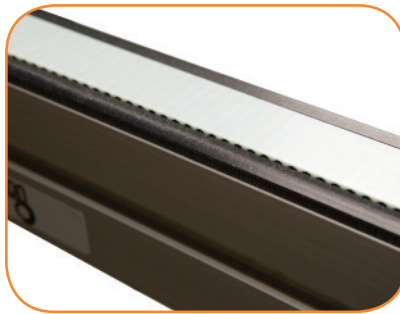

Medium Friction



Anti-Static Low Friction

BELT SPEEDS

Determine conveyor belt speed based on the gearmotor RPM in gearmotor tables on pages 38-40.

Fixed Speed

60 Hz Gearmotors		
Belt Speed		
Gearmotor RPM	ft/min	m/min
29	19	5.8
43	28	8.5
86	56	17.1
173	114	34.7
50 Hz Gearmotors		
23	15	4.6
35	23	7
70	46	14
140	92	28

Variable Speed

60 Hz Gearmotors		
Belt Speed		
Gearmotor RPM	ft/min	m/min
29	1.9 – 19	0.6 – 5.8
43	2.8 – 28	0.9 – 8.5
86	5.6 – 56	1.7 – 17.1
173	11 – 114	3.4 – 34.7
50 Hz Gearmotors		
23	7.5 – 19	2.3 – 5.8
35	12 – 29	3.7 – 8.8
70	23 – 58	7.0 – 17.7
140	46 – 116	14 – 35.3

Note: Due to the wide variety of drive setups and applications, point of installation guarding is the responsibility of the end user.

Note: Dimensions = in (mm)

Standard Load, Fixed Speed

Chart 1 90° eDrive NEMA C-Face

- Sealed gearmotor
- NEMA 42 CZ C Face
- Totally enclosed, fan cooled
- 115V 1 phase includes switch, cord and overload protection
- 208-230/460 Volts, 3 phase wiring by others
- 60 Hz
- Order 3 phase starter separately, see page 42

Regulatory Approvals: CE, RoHS

Part Number	RPM	Gearmotor Type	1 Phase			3 Phase			in.-lbs.	Nm	3 Phase Starter Chart
			Hp	kW	FLA	Hp	kW	FLA			
62M060ES4(vp)FN	29	S	0.25	0.19	3.1	0.38	0.28	1.9 / 0.95	134 / 134	15.1 / 15.1	L
62M040ES4(vp)FN	43	S	0.25	0.19	3.1	0.38	0.28	1.9 / 0.95	160 / 160	18.1 / 18.1	L
62M020ES4(vp)FN	86	S	0.25	0.19	3.1	0.38	0.28	1.9 / 0.95	133 / 151	15 / 17.1	L
62M010ES4(vp)FN	173	S	0.25	0.19	3.1	0.38	0.28	1.9 / 0.95	75 / 114	8.5 / 12.9	L

(vp) = Voltage and Phase 11 = 115V, 1 phase 23 = 208 - 230 / 460V, 3 phase

Chart 2 eDrive IEC C-Face

- Sealed gearmotor
- IEC 63 B5 C Face
- IP 55 protection rating
- Totally enclosed, fan cooled
- Non-reversing
- 50 Hz
- Order starter separately, see page 42

Regulatory Approvals: CE

Part Number	RPM	Gearmotor Type	1Ph kW	1 Ph FLA	3 Ph kW	3 Ph FLA	Nm	Starter Chart
			62Z060ES4(vp)FN	23	S	0.18		
62Z040ES4(vp)FN	35	S	0.18	1.6	0.25	1.56 / 0.9	26.9 / 35.5	I
62Z020ES4(vp)FN	70	S	0.18	1.6	0.25	1.56 / 0.9	16 / 21.2	I
62Z010ES4(vp)FN	140	S	0.18	1.6	0.25	1.56 / 0.9	8.7 / 11.4	I

(vp) = Voltage and Phase 21 = 230V, 1 phase 23 = 230V, 3 phase 43 = 400V, 3 phase

Standard Load, Variable Speed

Chart 28 90° eDrive NEMA C-Face VFD Rated

- Sealed gearmotor
- NEMA 42 CZ C Face
- Totally enclosed, fan cooled
- 208-230/460 Volts, 3 phase wiring by others
- 10-60 Hz
- Order 3 phase starter separately, see page 42

Regulatory Approvals: CE, RoHS

Part Number	RPM	Gearmotor Type	Hp	kW	FLA	in.-lbs.	Nm	Variable Speed Control Chart
			62M060ES423EN	29	S	0.38	0.28	
62M040ES423EN	43	S	0.38	0.28	1.9 / 0.95	160	18.1	D or E
62M020ES423EN	86	S	0.38	0.28	1.9 / 0.95	151	17.1	D or E
62M010ES423EN	173	S	0.38	0.28	1.9 / 0.95	114	12.9	D or E

Standard Load, Variable Speed (continued)

Chart 9 90° eDrive IEC C-Face VFD Rated

- Variable frequency drive, 25-63 Hz
- Sealed gearmotor
- IEC 63 B5 C Face
- IP 55 protection rating
- Totally enclosed, fan cooled
- 230/400 Volts, 3 phase
- Order controller separately, see page 41

eDrive®

Regulatory Approvals
CE

Part Number	RPM	Gearmotor Type	3 Ph kW	3 Ph FLA	Nm*	Vari-Speed Control Chart
62Z060ES423EN	23	S	0.25	1.56 / 0.9	36	B
62Z040ES423EN	35	S	0.25	1.56 / 0.9	35.5	B
62Z020ES423EN	70	S	0.25	1.56 / 0.9	21.2	B
62Z010ES423EN	140	S	0.25	1.56 / 0.9	11.4	B

* = At 50 Hz

Heavy Load, Fixed Speed

Chart 6 90° eDrive NEMA C-Face

- Sealed gearmotors
- NEMA 56 C face
- Totally enclosed, fan cooled
- 115V 1 phase includes switch, cord and overload protection
- 208-230/460 Volts 3 phase wiring by others
- 60 Hz
- Order 3 phase starter separately, see page 42

Regulatory Approvals
CE
UL
RoHS

Part Number	RPM	Gearmotor Type	1 Phase			3 Phase			in.-lbs.	Nm	Starter Chart
			Hp	kW	FLA	Hp	kW	FLA			
32M060ES4(vp)FN	29	H	0.5	0.37	5.7	0.5	0.37	2.1-2 / 1.0	319	36	M
32M040ES4(vp)FN	43	H	0.5	0.37	5.7	0.5	0.37	2.1-2 / 1.0	378	42.7	M
32M020ES4(vp)FN	86	H	0.5	0.37	5.7	0.5	0.37	2.1-2 / 1.0	285	32.2	M
32M010ES4(vp)FN	173	H	0.5	0.37	5.7	0.5	0.37	2.1-2 / 1.0	153	17.3	M

(vp) = Voltage and Phase 11 = 115V, 1 phase 23 = 208 - 230 / 460V, 3 phase

Chart 8 90° eDrive IEC C-Face

- Sealed gearmotor
- IEC 71 B5 C face for 0.37 kW Motor
- IEC 63 B5 C face for 0.18 kW Motor
- IP55 protection rating
- Totally enclosed, fan cooled
- Non-reversible
- 50 Hz
- Order starter separately, see page 42

Regulatory Approvals
CE
UL
RoHS

Part Number	RPM	Gearmotor Type	1Ph kW	1 Ph FLA	3 Ph kW	3 Ph FLA	Nm	Starter Chart
62Z060ES4(vp)FN	23	L	0.18	1.6	0.25	1.56 / 0.90	36 / 36	I
62Z040ES4(vp)FN	35	L	0.18	1.6	0.25	1.56 / 0.90	26.9 / 35.5	I
32Z020ES4(vp)FN	70	S	0.37	2.6	0.37	2.1 / 1.2	32.2 / 32.2	J
32Z010ES4(vp)FN	140	S	0.37	2.6	0.37	2.1 / 1.2	17.3 / 17.3	J

(vp) = Voltage and Phase 21 = 230V, 1 phase 23 = 230V / 460V, 3 phase 43 = 400V, 3 phase

Heavy Load, Variable Speed

Chart 10		90° eDrive NEMA C-Face VFD Rated							Regulatory Approvals CE RoHS																																													
<ul style="list-style-type: none"> Variable frequency drive, 6 - 60 Hz Sealed gearmotor NEMA 56 C Face Totally enclosed, fan cooled 230/460 Volts, 3 Phase Order controller separately, see page 41 										<table border="1"> <thead> <tr> <th>Part Number</th> <th>RPM*</th> <th>Gearmotor Type</th> <th>3 Ph Hp</th> <th>3 Ph kW</th> <th>3 Ph FLA</th> <th>in.-lbs.*</th> <th>Nm*</th> <th>Vari-Speed Control Chart</th> </tr> </thead> <tbody> <tr> <td>32M060ES423EN</td> <td>29</td> <td>H</td> <td>0.75**</td> <td>0.55</td> <td>2.6 / 1.3</td> <td>319</td> <td>36</td> <td>D or E</td> </tr> <tr> <td>32M040ES423EN</td> <td>43</td> <td>H</td> <td>0.75**</td> <td>0.55</td> <td>2.6 / 1.3</td> <td>378</td> <td>42.7</td> <td>D or E</td> </tr> <tr> <td>32M020ES423EN</td> <td>86</td> <td>H</td> <td>0.75**</td> <td>0.55</td> <td>2.6 / 1.3</td> <td>285</td> <td>32.2</td> <td>D or E</td> </tr> <tr> <td>32M010ES423EN</td> <td>173</td> <td>H</td> <td>0.75**</td> <td>0.55</td> <td>2.6 / 1.3</td> <td>153</td> <td>17.3</td> <td>D or E</td> </tr> </tbody> </table>	Part Number	RPM*	Gearmotor Type	3 Ph Hp	3 Ph kW	3 Ph FLA	in.-lbs.*	Nm*	Vari-Speed Control Chart	32M060ES423EN	29	H	0.75**	0.55	2.6 / 1.3	319	36	D or E	32M040ES423EN	43	H	0.75**	0.55	2.6 / 1.3	378	42.7	D or E	32M020ES423EN	86	H	0.75**	0.55	2.6 / 1.3	285	32.2	D or E	32M010ES423EN	173	H	0.75**	0.55	2.6 / 1.3	153	17.3
Part Number	RPM*	Gearmotor Type	3 Ph Hp	3 Ph kW	3 Ph FLA	in.-lbs.*	Nm*	Vari-Speed Control Chart																																														
32M060ES423EN	29	H	0.75**	0.55	2.6 / 1.3	319	36	D or E																																														
32M040ES423EN	43	H	0.75**	0.55	2.6 / 1.3	378	42.7	D or E																																														
32M020ES423EN	86	H	0.75**	0.55	2.6 / 1.3	285	32.2	D or E																																														
32M010ES423EN	173	H	0.75**	0.55	2.6 / 1.3	153	17.3	D or E																																														

* = At 60 Hz ** = Motor is de-rated to 0.5 Hp (2.2 / 1.1 amp) for full torque throughout the speed range.

Chart 11		90° eDrive IEC C-Face VFD Rated					Regulatory Approvals CE RoHS SE																																			
<ul style="list-style-type: none"> Variable frequency drive, 25 - 63 Hz Sealed gearmotor IEC 63 B5 C Face for 0.18 kW Motor IEC 71 B5 C Face for 0.37 kW Motor IP 55 protection rating Totally enclosed, fan cooled 230/400 Volts, 3 Phase Order controller separately, see page 41 								<table border="1"> <thead> <tr> <th>Part Number</th> <th>RPM</th> <th>Gearmotor Type</th> <th>3 Ph kW</th> <th>3 Ph FLA</th> <th>Nm*</th> <th>Vari-Speed Control Chart</th> </tr> </thead> <tbody> <tr> <td>62Z060ES423EN</td> <td>23</td> <td>L</td> <td>0.25</td> <td>1.56 / 0.90</td> <td>36</td> <td>B</td> </tr> <tr> <td>62Z040ES423EN</td> <td>35</td> <td>L</td> <td>0.25</td> <td>1.56 / 0.90</td> <td>35.5</td> <td>B</td> </tr> <tr> <td>32Z020ES423EN</td> <td>70</td> <td>S</td> <td>0.37</td> <td>2.1 / 1.2</td> <td>32.2</td> <td>B</td> </tr> <tr> <td>32Z010ES423EN</td> <td>140</td> <td>S</td> <td>0.37</td> <td>2.1 / 1.2</td> <td>17.3</td> <td>B</td> </tr> </tbody> </table>	Part Number	RPM	Gearmotor Type	3 Ph kW	3 Ph FLA	Nm*	Vari-Speed Control Chart	62Z060ES423EN	23	L	0.25	1.56 / 0.90	36	B	62Z040ES423EN	35	L	0.25	1.56 / 0.90	35.5	B	32Z020ES423EN	70	S	0.37	2.1 / 1.2	32.2	B	32Z010ES423EN	140	S	0.37	2.1 / 1.2	17.3
Part Number	RPM	Gearmotor Type	3 Ph kW	3 Ph FLA	Nm*	Vari-Speed Control Chart																																				
62Z060ES423EN	23	L	0.25	1.56 / 0.90	36	B																																				
62Z040ES423EN	35	L	0.25	1.56 / 0.90	35.5	B																																				
32Z020ES423EN	70	S	0.37	2.1 / 1.2	32.2	B																																				
32Z010ES423EN	140	S	0.37	2.1 / 1.2	17.3	B																																				

* = At 50 Hz

CE Note: When buying a gearmotor only without the starter, the customer must supply their own on/off switch and motor overload protection to comply with the CE Safety Directive.

FLA = Full Load Amperes

Some motors and gear reducers may normally operate hot to the touch. Consult factory for specific operating temperatures. Note: Dimensions = in (mm)

Variable Speed Controllers

Chart B VFD Controller, Full CE Compliance

- VFD control
- IP 65 enclosure
- EMC filter
- Variable speed
- Mounting hardware
- Line cord and motor cord
- Motor cord only on 400V

Regulatory Approvals
CE
UL US

Part Number	Input Volts	Input Phase	Input Hz	Output Volts	Output Phase	Max Kw*	Max Amps	Reversing
62UV2121	230	1	50	230	3	0.75	4.2	Yes
62UV4341	400	3	50	400	3	0.75	2.1	Yes

In order for this drive to meet full CE requirements for European application a separate CE approve RFI filter must be installed. Product shown in chart B above have this filter pre-installed and are recommended for use in the European Union.

Chart D Full Feature VFD Controller

- Full feature VFD control
- NEMA 4 enclosure
- Digital display
- Keypad with Start/Stop, Forward/Reverse and speed variations
- Includes cord to motor
- Power to controller by others for 230V & 460V input
- 62MV1122 includes line cord to controller
- Mounting hardware

Regulatory Approvals
CE
UL US

Part Number	Input Volts	Input Phase	Input Hz	Output Volts	Output Phase	Max Kw*	Max Amps	Reversing
32MV1122	115	1	60	230	3	0.5	2.2	Yes
32MV2122	230	1	60	230	3	0.5	2.2	Yes
32MV1121	115	1	60	230	3	1.0	4.0	Yes
32MV2121	230	1	60	230	3	1.0	4.0	Yes
32MV2322	230	3	60	230	3	0.5	2.2	Yes
32MV4341	460	3	60	460	3	1.0	2.0	Yes

In order for this drive to meet full CE requirements for European application a separate CE approve RFI filter must be installed. Product shown in chart B above have this filter pre-installed and are recommended for use in the European Union.

Chart E Basic VFD Controller

- Variable frequency drive
- Aluminum backplate with plastic enclosure
- Lighted on / off switch
- Speed potentiometer
- Forward / Stop / Reverse switch (22MV1122BR)
- Includes motor cord and power cord
- Includes mounting brackets and hardware
- UL listed and RoHS compliant

Regulatory Approvals
CE
RoHS
UL US

Part Number	Input Volts	Input Phase	Input Hz	Output Volts	Output Phase	Max Kw*	Max Amps	Reversing
22MV1122B	115	1	60	230	3	0.5	2.4	No
22MV1122BR	115	1	60	230	3	0.5	2.4	Yes

In order for this drive to meet full CE requirements for European application a separate CE approve RFI filter must be installed. Product shown in chart B above have this filter pre-installed and are recommended for use in the European Union.

* = See FLA from motor charts **Note:** Dimensions = in (mm)

Note: Due to the wide variety of drive setups and applications, point of installation guarding is the responsibility of the end user.

Note: Dimensions = in (mm)

Manual Motor Starters

Manual motor starts are manual electronic disconnects that provide motor overload protection and are required by the National Electric Code (NEC) for safe motor operation.

- IP 55 Enclosure
- Push button Start / Stop
- Includes mounting hardware

Regulatory Approvals

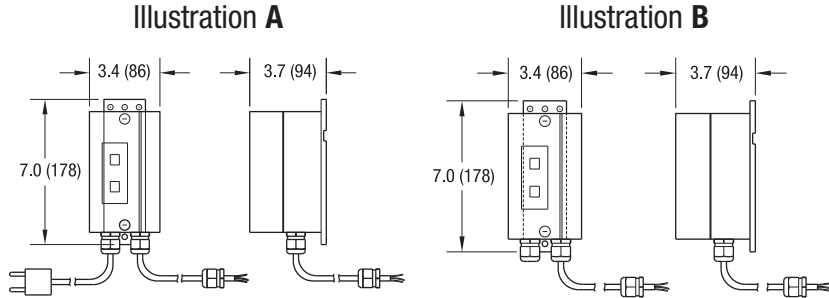



Chart I		230/400V 50Hz to 2.5 amp		
<ul style="list-style-type: none"> • 230 Volts, 1 phase includes cord, plug and starter • 230/400 Volts, 3 phase wiring to starter by others • Wiring between motor and starter provided when ordered together • 50 Hz 				
Part Number	In Volts	In Phase	Amp Range	Illustration
62(c)M21T	230	1	1.6 - 2.5	A
62(c)M23T	230	3	1.0 - 1.6	B
62(c)M43T	400	3	0.63 - 1.0	B

Chart J		230/400V 50 Hz to 4 amp		
<ul style="list-style-type: none"> • 230 Volts, 1 phase includes cord, plug and starter • 230/400V, 3 phase wiring to starter by others • Wiring between motor and starter provided when ordered together • 50 Hz 				
Part Number	In Volts	In Phase	Amp Range	Illustration
62(c)M21J	230	1	2.5 - 4.0	A
62(c)M23J	230	3	1.6 - 2.5	B
62(c)M43J	400	3	1.0 - 1.6	B

Chart L		230/460V 60 Hz to 1.6 amp		
<ul style="list-style-type: none"> • 230/460 Volts, 3 phase wiring to starter by others • Wiring between motor and starter provided when ordered together • 60 Hz 				
Part Number	In Volts	In Phase	Amp Range	Illustration
62MM23L	230	3	1.0 - 1.6	B
62MM43L	460	3	0.4 - .63	B

Chart M		230/460V 60Hz to 2.5 amp		
<ul style="list-style-type: none"> • 230/460 Volts, 3 phase wiring to starter by others • Wiring between motor and starter provided when ordered together • 60 Hz 				
Part Number	In Volts	In Phase	Amp Range	Illustration
62MM23M	208	3	1.6 - 2.5	B
62MM43M	-230 460	3	1.0 - 1.6	B



Fixed Height Support Stands

- (2) Versions
 - Standard 2-Leg version for base conveyor mounting
 - 3-Leg version for corner conveyor mounting
- 12" (305 mm) minimum TOB height
- 72" (1829 mm) maximum TOB height
- Aluminum construction with T-Slot mounting for bolt on accessories and structure
- Provide ±2 inch (50 mm) of adjustment
- Optional diagonal brace, see page 44.

Stand Chart					
Stand Width	160 mm	240 mm	320 mm	400 mm	480 mm
Part Number Reference	160	240	320	400	480

Stand Chart			
Stand Height	12" - 16" (305-406 mm)	1" increments up to...	68" - 72" (1727-1829 mm)
Part Number Reference	1216	0101 increments up to..	6872

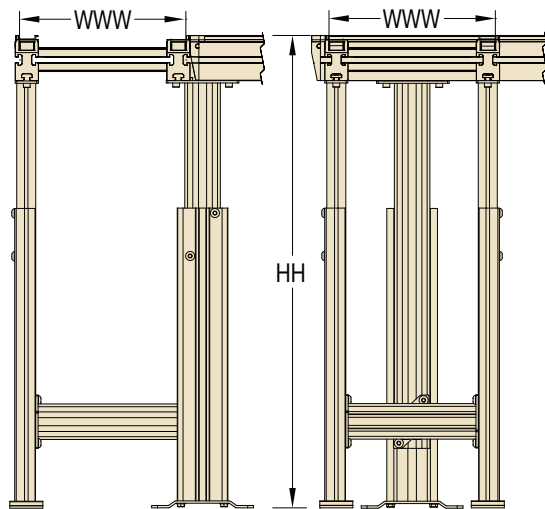

3 Leg Corner Version

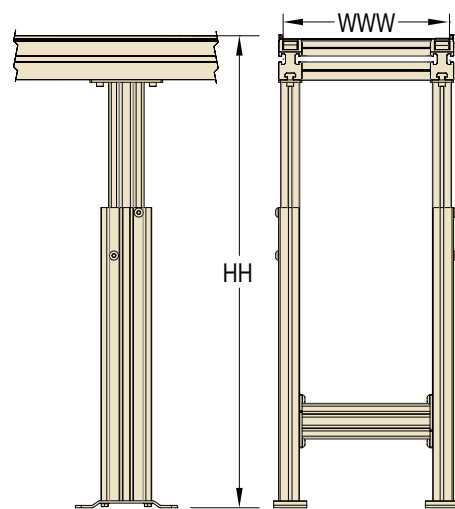

2 Leg Version

*When motor is mounted vertical (position 4) stand minimum height 16".

2200 Series Precision Move Pallet System Stands												
2	2	D	S	2	M	WWW	-	L	H	U	H	F
Footing: F = Fixed Foot Tallest Height to TOB (in inches) Lowest Height to TOB (in inches) Conveyor Width Reference: 160 = 160 mm 240 = 240 mm 320 = 320 mm 400 = 400 mm 480 = 480 mm Documentation Language: M = US-English Post Type: 2 = 2 Leg Stand 3 = 3 Leg Stand												

Note: Due to the wide variety of conveyor and stand options along with possible configurations, stability of the final setup is the responsibility of the end user.
Note: Due to the wide variety of drive setups and applications, point of installation guarding is the responsibility of the end user. **Note:** Dimensions = in (mm)

Conveyor Tie Bracket

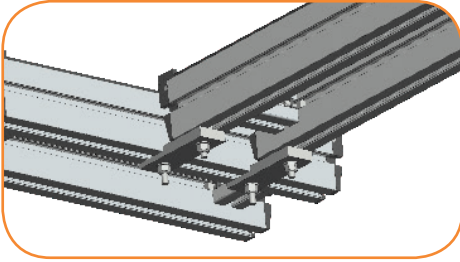

Specifications

- Tie plate for connecting conveyors at 90 degree relationship
- Can be configured for flat transfer or 1/4" height change
- Includes a pair of tie plate assemblies
- Includes all mounting hardware

Part Number	204736
-------------	--------

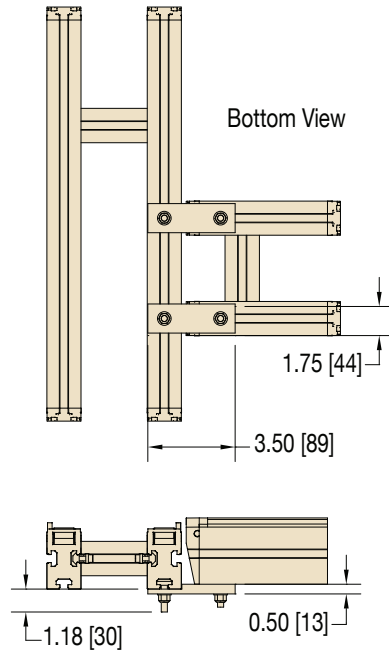

Diagonal Bracing



Specifications

- For use on steel, aluminum and single post support stands with casters
- Metric fastener mounting hardware included
- For use on all stands with casters and any stands over 72" (1829 mm) tall
- One brace per stand for conveyors up to 24" wide (610 mm)
- Two braces per stand for conveyors over 24" wide (610 mm)

Part Number	Description
39MB-TS	for stands up to 30" tall (762 mm)
39MB-TT	for stands over 30" tall (762 mm)

Pallet Sensor Bracket, Vertical

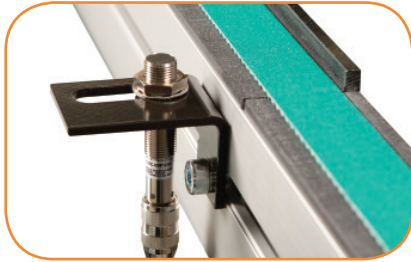

Specifications

- Standard mounting for 12 mm barrel proximity sensors
- Sensor faces upward sensing pallet pick-up on bottom of pallet
- Requires a minimum of 1" long threaded portion on sensor
- Includes all mounting hardware
- Proximity sensor with 4 mm sensory range recommended

Part Number	205557
-------------	--------

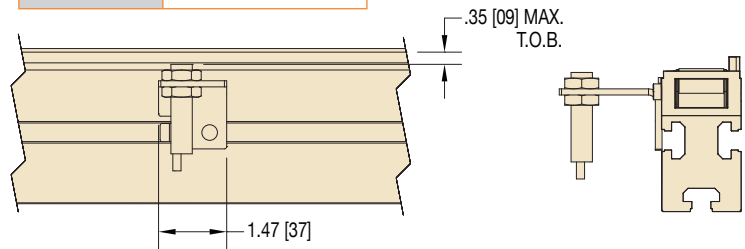

Pallet Sensor Bracket, Horizontal



Specifications

- Standard mounting for 12 mm barrel proximity sensors
- Sensor faces inward sensing pallet pick-up on outside of pallet
- Requires a minimum of 1" long threaded portion on sensor
- Includes all mounting hardware
- Not for use on pallet sides with bumpers
- Proximity sensor with 4 mm sensory range recommended

Part Number	205574
-------------	--------

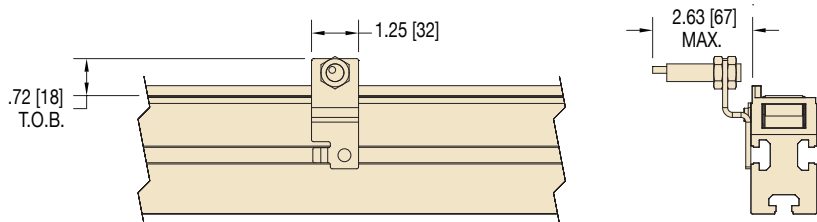

Photo Sensor Bracket



Specifications

- Standard mounting for 18 mm barrel / nose mount reflective sensors
- Adjustable in height and angle
- Includes a reflector
- Includes all mounting hardware

Part Number	Photo Eye Mount Type
75M-PM-1	Reflective
75M-PM-3	Through Beam
75M-PM-5	Convergence

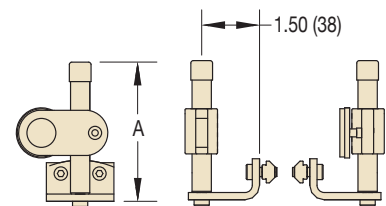

A = 3.61" (92) for 2" Adjustment

Side Tables

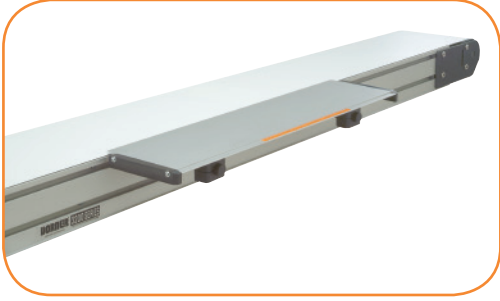

Specifications

- Provides a 6" (152 mm) or 12" (305 mm) wide working surface
- Adjusts in/out and up/down
- Can be positioned anywhere along the conveyor
- Anodized aluminum work surface
- Max load: 5 lbs/ft (6 kg/m), use Adjustable Tie Brackets for added capacity
- Available in 1' (305 mm) increments from 1' (305 mm) to 99' (30,175 mm)

Side Tables

27MSF T - 06 LLLL

Table Length (ex. 0200 = 2')

Table Width: 06 = 6" 12 = 12"

Conveyor / Table Type:

1 = One Side

2 = Two Sides

Example: 27MSF1-060200

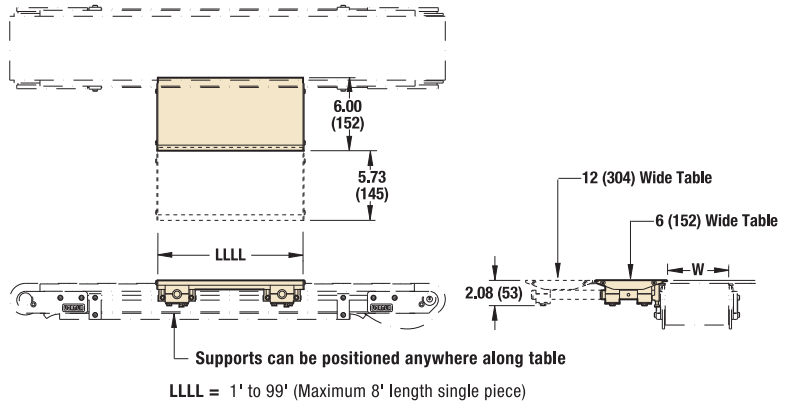

T-Slot Accessories

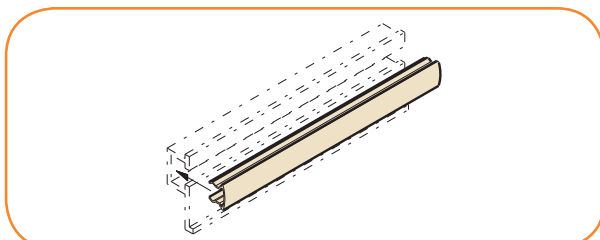
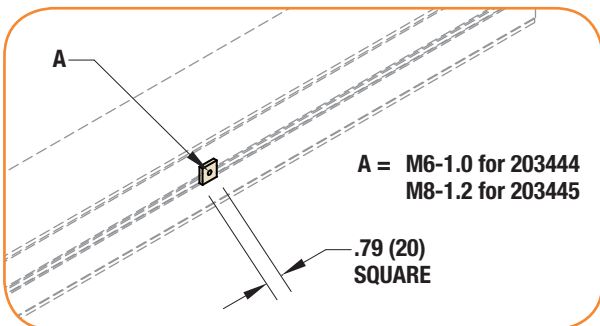
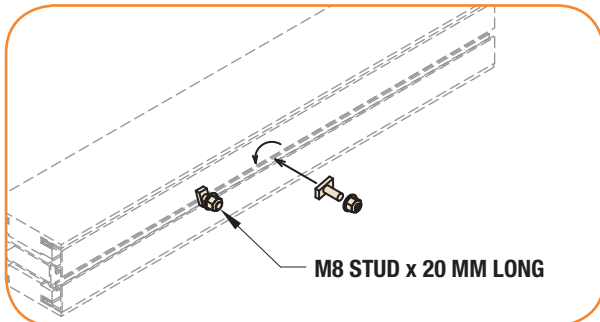
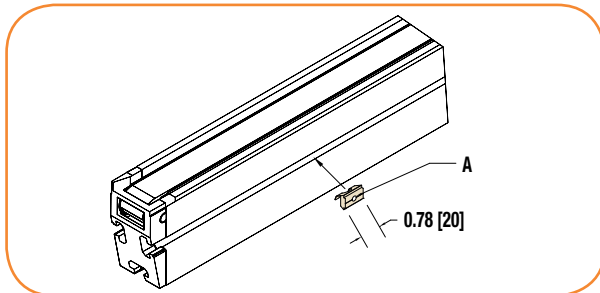
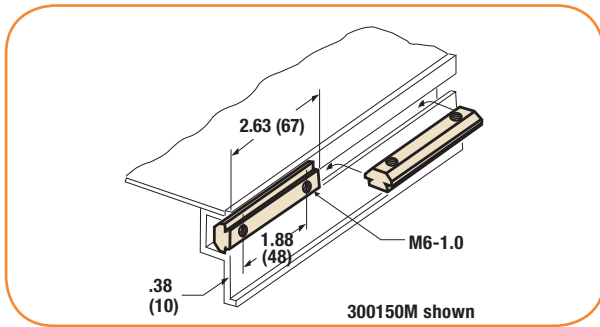

T-Bars

- Mounts in T-Slot to attach heavy accessories
- Fits conveyor and stands

Part Number	639971M (1 hole T-bar, M6-1.0, .75" long) 202390M (1 hole T-bar, M8-1.25, .63" long) 643874M (.75" centers, 2 hole T-bar, M6-1.0, 1.5" long) 200626M (.875" centers, 2 hole T-bar, M6-1.0, 1.62" long) 200830M (1.0" centers, 2 hole T-bar, M6-1.0, 1.75" long) 639717M (1.25" centers, 2 hole T-bar, M6-1.0, 2.0" long) 300150M (1.875" centers, 2 hole T-bar, M6-1.0, 2.62" long) 300536M (2.125" centers, 2 hole T-bar, M6-1.0, 2.88" long)
-------------	---

Spring Nuts

- For mounting accessories to conveyor
- Spring retains position in T-Slot
- .78" (20 mm) long

Part Number	205504 M4 x .7 205505 M5 x .8 205506 M6 x 1.0 205508 M8 x 1.25
-------------	---

T-Bolt Hardware

- For mounting accessories to conveyor
- Twist in T-Bolt for mounting accessories
- M8-1.25 male threaded post
- (2) lengths available; 20 mm long and 35 mm long
- 20mm long used to mount up to 0.25" plate thickness
- 35mm long used to mount up to 0.85" plate thickness
- Provided in a package of 5 T-Bolts and flanged locknuts

Part Number	203446 (20 mm long) 203447 (35 mm long)
-------------	--

Slide In Square Nuts

- For mounting accessories to conveyor
- Must be slid in at section break
- (2) thread sizes available: M6-1.0 or M8-1.25
- Provided in a package of 5 nuts

Part Number	203444 (M6-1.0) 203445 (M8-1.25)
-------------	-------------------------------------

T-Slot Cover

- Snaps into conveyor and aluminum stand T-Slots
- Black plastic extrusion
- Can be trimmed to fit

Part Number	645656P (Per 1' (305 mm) of length)
-------------	-------------------------------------

Regulatory Approvals:







Conveyors:

All Dorner 2200 Series Precision Move Pallet Systems standard conveyors (not including gearmotors and controllers) are CE approved. CE approval follows the provisions of the following directives; Machine Directive 2006/42/EC, EU Low Voltage Directive 2006/95/EC, and EMC Directive 2004/108/EC. All conveyors are marked with the CE symbol on the Dorner serial number tag located on the conveyor frame. Contact the factory for the CE Declaration of Conformity.

All Dorner 2200 Series Precision Move Pallet Systems standard conveyors (not including gearmotors and controllers) are designed and manufactured in accordance with the restrictions defined in the “Restriction of Hazardous Substances” directive, citation 2002/95/EC, commonly known as RoHS. All conveyors are marked with the RoHS symbols on the Dorner serial number tag located on the conveyor frame.

Gearmotors and Controllers:

All Dorner 2200 Series Precision Move Pallet Systems gearmotors and controllers carry one or more of the following approvals. Products are not covered by each approval. Please see the appropriate part number on the Gearmotor and controller charts located in this manual. In addition, regulatory symbols are located on the product information tags located on the product.

	<p>CE marking on a product is a manufacturer's declaration that the product complies with the essential requirements of the relevant European health, safety and environmental protection legislation, in practice by the Product Directives. CE Marking on a product ensures the free movement of the product within the European Union (EU).</p>
	<p>This directive restricts (with exceptions) the use of six hazardous materials in the manufacture of various types of electronic and electrical equipment. It is closely linked with the Waste Electrical and Electronic Equipment Directive (WEEE) 2002/96/EC which sets collection, recycling and recovery targets for electrical goods and is part of a legislative initiative to solve the problem of huge amounts of toxic e-waste.</p>
	<p>The UL Recognized Component mark is for products intended to be installed in another device, system or end product. This Recognized Component Mark is for the United States only. When a complete product or system containing UL Recognized Components is evaluated, the end-product evaluation process can be streamlined.</p>
	<p>The UL Recognized Component mark is for products intended to be installed in another device, system or end product. This Recognized Component Mark is for the United States and Canada. When a complete product or system containing UL Recognized Components is evaluated, the end-product evaluation process can be streamlined.</p>
	<p>CSA International (Canadian Standards Association), is a provider of product testing and certification services for electrical, mechanical, plumbing, gas and a variety of other products. Recognized in the U.S., Canada and around the world, CSA certification marks indicate that a product, process or service has been tested to a Canadian or U.S. standard and it meets the requirements of an applicable CSA standard or another recognized document used as a basis for certification.</p>
	<p>The UL Listing Mark means UL found that representative product samples met UL's safety requirements. These requirements are primarily based on UL's own published standards for safety. The C-UL-US Mark indicates compliance with both Canadian and U.S. requirements. The products with this type of Mark have been evaluated to Canadian safety requirements and U.S. safety requirements.</p>

Clean Room Certifications:

The 2200 Series Precision Move Pallet Systems Conveyors are often used in clean room applications where the generation of particulates from the conveyor are a concern. In these applications the correct installation and application of the conveyor is critical to the proper running of the conveyor and minimizing the dust generated by the conveyor belt or modular belt. The end user must ensure that the conveyor belts are properly tracked and product accumulation is minimized to providing minimal dust generation.

All of the 2200 Series products are designed and constructed to be used in clean room environments. The following 2200 Series products have gone through third party testing and certification and are certified for use in ISO Standard 14644-1 Class 5 and Federal Standard 209 Class 100 Clean Room applications.

- 1100 Series Belted Conveyor**
- 2200 Series Belted Conveyor**
- 2200 Series Precision Move Conveyor**
- 2200 Series SmartFlex Conveyor**
- 3200 Series Belted Conveyor**
- 3200 Series Modular Belted Conveyor**
- 3200 Series Precision Move Conveyor**



Contact the factory for copy of the certification.

Belting Chemical Resistance:

Belting:	
The following is a list of the top coat materials used in 2200 Series Precision Move Conveyor belting:	
Material	Belt Number
Urethane	1D, 2D, 6D

Resistance to Materials: Belting					
The following table provides the resistance to belt materials used in the conveyor to several chemicals. Application testing is recommended to determine long term material durability.					
Legend: 1 = Good resistance 3 = Limited resistance 4 = Not recommended					
Materials	Urethane	Materials	Urethane	Materials	Urethane
Chemicals		Calcium chloride	1	Ethyl alcohol, non-denatured 96%	1
Acetic acid (glacial acetic acid)	4	Calcium nitrate	1	Ethyl alcohol, non-denatured 50%	1
Acetic acid 10 %	3	Calcium sulphate	1	Ethyl alcohol, non-denatured 10%	1
Acetic anhydride	3	Carbon disulphide	4	Ethyl benzene	4
Acetone	4	Carbon tetrachloride	3	Ethyl chloride	4
Aluminum salts	1	Chlorine, liquid	4	Ethylene chloride	4
Alum	1	Chlorine, gaseous, dry	4	2-Ethyl hexanol	1
Ammonia, aqueous	3	Chlorine, gaseous, wet	4	Formaldehyde	1
Ammonia, gaseous	1	Chlorine water	4	Formic acid, dilute	4
Ammonium acetate	1	Chlorobenzene	4	Glycerine	1
Ammonium carbonate	1	Chloroform	4	Glycerine, aqueous	1
Ammonium chloride	1	Chlorosulphonic acid	4	Glycol	1
Ammonium nitrate	1	Chromic acid	4	Glycol, aqueous	1
Ammonium phosphate	1	Chromium salts	1	Heptane	1
Ammonium sulphate	1	Chromium trioxide	1	Hexane	1
Amyl alcohol	1	Citric acid	4	Hydrochloric acid, conc.	3
Aniline	3	Copper salts	1	Hydrochloric acid 10 %	3
Barium salts	1	Cresols	3	Hydrofluoric acid 40 %	4
Benzaldehyde	4	Cresols, aqueous	3	Hydrogen chloride, gaseous, dilute	3
Benzine (see also Motor fuels)	1	Cyclohexane	4	Hydrogen chloride, gaseous, conc.	3
Benzoic acid	1	Cyclohexanol	4	Hydrogen peroxide 10%	3
Benzol	3	Cyclohexanone	4	Hydrogen sulphide	3
Boric acid	1	Decahydronaphthalene	4	Iron salts (sulphate)	1
Boric acid, solution	1	Dibutyl phthalate	3	Isooctane	1
Bromine	4	Diethyl ether	4	Isopropyl alcohol	1
Bromine water	4	Dimethyl formamide	4	Lactic acid	1
Butane, gaseous	1	1.4 Dioxan	4	Magnesium salts	1
Butane, liquid	1	Ether	4	Mercury	1
Butyl acetate	4	Ethyl acetate	4	Mercury salts	1
n-Butyl alcohol	1	Ethyl alcohol, non-denatured 100%	1	Methyl alcohol, aqueous 50 %	3

Resistance to Materials: Belting

The following table provides the resistance to belt materials used in the conveyor to several chemicals. Application testing is recommended to determine long term material durability.

Legend: 1 = Good resistance | 3 = Limited resistance | 4 = Not recommended

Materials	Urethane	Materials	Urethane	Materials	Urethane
Methyl alcohol (methanol)	1	Sodium chlorate	1	Benzene	1
Methyl ethyl ketone	4	Sodium chloride (common salt)	1	Bleaching lye (12.5%)	1
Methylene chloride	4	Sodium hydroxide (caustic soda)	4	Bone oil	1
Naphthalene	3	Sodium hypochlorite	1	Borax	1
Nickel salts	1	Sodium nitrate	1	Brake fluid* Bosch	1
Nitric acid	4	Sodium nitrite	1	Brake fluid* Skydrol	4
Nitrobenzene	4	Sodium perborate	1	Chloride of lime (aqueous suspension)	1
Octane (see also isooctane)	1	Sodium phosphate	1	Chlorine (active)	4
Oleic acid	1	Sodium sulphate (Glauber salt)	1	Chrome baths* (technical)	1
Oxalic acid	1	Sodium sulphide	1	Chromosulphuric acid	4
Ozone	1	Sodium sulphite	1	Cresol solution	3
Perchloroethylene	4	Sodium thiosulphate (fixing salt)	1	Diesel oil	1
Phenol	3	Stearic acid	1	Fertilizer salts	1
Phenol, aqueous	4	Succinic acid	1	Fixing salt	1
Phosphoric acid 85 %	4	Sulphur	1	Floor wax	1
Phosphoric acid 50 %	1	Sulphur dioxide	3	Formalin	1
Phosphoric acid 10 %	1	Sulphuric acid 96%	4	Fuel oils*	1
Phosphorus pentoxide	1	Sulphuric acid 50%	4	Furniture polish*	1
Potash lye 50 %	4	Sulphuric acid 25%	4	Gypsum	1
Potash lye 25 %	4	Sulphuric acid 10%	4	Ink*	1
Potash lye 10 %	4	Tartaric acids	1	Linseed oil	1
Potassium carbonate (potash)	1	Tetrachloroethane	4	Litex (styrene)	4
Potassium chlorate	1	Tetrachloroethylene (perchloroethylene)	4	Mineral oils (non-aromatic)	1
Potassium chloride	1	Tetrahydrofuran	4	Moth balls	3
Potassium dichromate	1	Tetrahydronaphthalene	4	Diesel oil*	1
Potassium iodide	1	Thiophene	4	Petrol (gasoline) DIN51635	1
Potassium nitrate	1	Tin II chlorides	1	Petrol, regular	1
Potassium permanganate	1	Toluene	4	Petrol, super	3
Potassium persulphate	1	Trichloroethylene	4	Motor oils*	1
Potassium sulphate	1	Urea, aqueous	1	Oil no. 3 (ASTM)	1
Propane, gaseous	1	Water	1	Oleum	4
Propane, liquid	1	Xylene	4	Paraffin	1
Pyridine	4	Zinc salts	1	Paraffin oil	1
Silver salts	1			Petroleum	1
Soda lye 50% (see potash lye)	4	Products		Petroleum ether	1
Soda lye 25%	4	Alum	1	Photographic developer	1
Soda lye 10%	4	Anti-freeze*	1		
Sodium bisulphite	1	Aqua regia	4		
Sodium carbonate (natron)	1	Asphalt	1		
Sodium carbonate (soda)	1	Battery acid	4		

Conveyor Noise Level (Decibel Ratings)

The actual noise level generated by the conveyor depends on several factors: the installation configuration, the product running on the conveyor, the surrounding equipment, the conveyor options and belt speed. The noise level generated by the conveyor is typically less than the general noise level of factory equipment.

Generally a higher belt speed will result in a higher noise level. In addition modular belt conveyors will run slightly louder than belted conveyors. The following charts provide basic decibel ratings for a typical conveyor arrangements.

2200 Series Precision Move Dual Strand Conveyors:

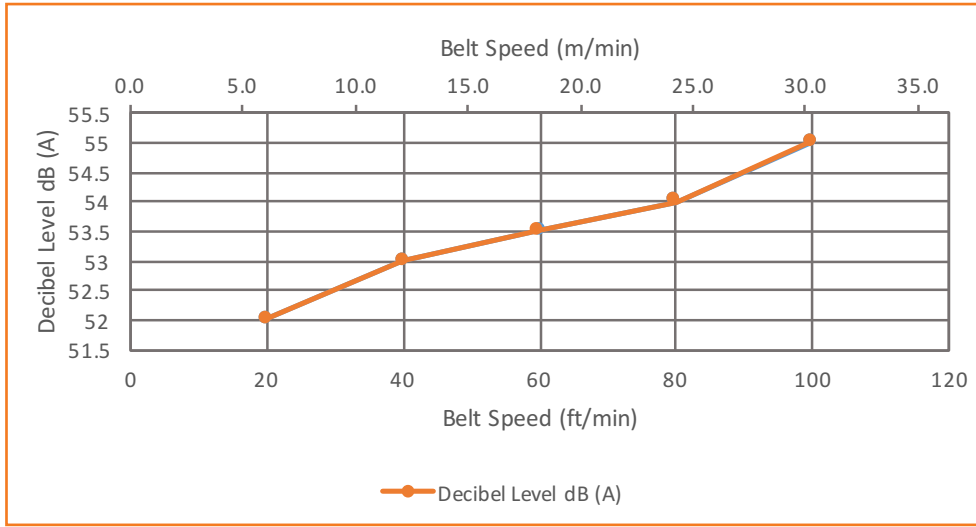

Belting and Coefficient of Friction

The coefficient of friction is used to determine the load a conveyor can carry. It affects a conveyor in two ways: the friction that exists between the conveyor belt and the bed surface, and if accumulating product the friction that exists between the conveyor top surface and the product.

Coefficient of Friction, between the bottom of the conveyor belt and bed surface

Product	Surfaces	Application Condition	Coefficient of Friction
2200 Series Precision Move Dual Strand Conveyor	Impregnated polyester fabric to plastic bed plate	Dry	0.30

Coefficient of Friction, between the top surface of conveyor belt and product:

2200 Series Precision Move Conveyors

The following table provides the coefficient of friction between steel product and various belt top surfaces. All factors below are assuming dry conditions.

Belt Number	Top Surface Material and Type	Coefficient of Friction
2D	Smooth medium urethane	0.50
1D, 6D	Impregnated polyester fabric	0.20

Calculating Conveyor Belt Speed

2200 Series Precision Move Conveyors:

To calculate the conveyor belt speed you need to know the following factors:

- Drive roller diameter
 - 2.51" (63.69mm) pitch diameter
- RPM of gearmotor

$$\text{Belt Speed (ft/min)} = (\text{Drive roller diameter}/12) * (3.14) * (\text{RPM of gearmotor})$$

Example:

2200 Series Precision Move Pallet Conveyor and the gearmotor. The gearmotor is a 10:1 ratio with 173 rpm output.

$$\text{Belt Speed (ft/min)} = (2.51/12) * (3.14) * (173)$$

$$\text{Belt speed (ft/min)} = 113.6 \text{ ft/min}$$

Calculating Conveyor Load Capacity

There are several factor that effect the overall conveyor load of the 2200 Series Precision Move conveyor. These include:

- Conveyor size and configuration
- Conveyor speed
- Application temperature
- Product Accumulation
- Number of starts and stops per hour

Located online at www.dornerconveyors.com is the Dorner conveyor configuration tool, DTools. This tool allows you to configure your conveyor layout and determine the maximum load capacity for the conveyor. It is suggested that this program be used to calculate the conveyor load as the calculation is quite complicated. This configuration program however does not take into account temperature, dirty conditions, and conveyor starts and stops. If these conditions are part of your application please use the load reducing factors as shown below.

$$\text{Maximum Load} = (\text{Load from DTools})(\text{Temperature Factor})(\text{Start/Stop Factor})$$

Temperature Factor		
Ambient temperature can negatively affect the capacity of the conveyor.		
Temperature F	Temperature C	Temperature Factor
-4	-20	1.0
32	0	1.0
68	20	1.0
104	40	0.9
140	60	0.8

Start / Stop Factor	
Frequent Start / Stops of the conveyor can negatively affect the capacity of the conveyor. All start / stop applications must use a soft start mechanism such as a Frequency Inverter with a 1 second acceleration cycle.	
Application Condition	Start / Stop Factor
Continuous Run or 1 start/stop per hour	1.0
Maximum 10 starts/stop per hour	0.83
Maximum 30 starts/stop per hour	0.70
Greater than 30 starts/stop per hour	0.62

Pallet Weights (lbs)

Pallet					
Pallet Width (mm)	Pallet Length (mm)	1/4" Alum Plate	1/2" Alum Plate	3/16" Steel Plate	1/4" Steel Plate
160	160	2.1	3.0	3.2	3.8
160	240	2.7	4.1	4.4	5.4
240	240	3.6	5.8	6.1	7.7
240	320	4.5	7.3	7.9	10.0
240	480	6.2	10.6	11.3	14.5
320	320	5.6	9.5	10.2	13.0
320	480	7.8	13.7	14.7	18.9
400	400	8.1	14.2	15.3	19.7
400	480	9.5	16.7	18.0	23.3
480	480	11.0	19.8	21.3	27.7

2200 Series Precision Move Pallet System Modules

Pneumatic Specifications								
Devise	Action	Bore Diameter	Stroke	Return Type	Force per Psi	Sensor Compatible	Fitting Tap Size	Fitting Tube Size
Lift and Locate	Lift Cylinder	1.75" (44 mm)	3" (76 mm)	Pneumatic	2.40	Yes	1/8 NPT	1/4"
Lift and Transfer	Lift Cylinder	2" (51 mm)	0.6" (15 mm)	Pneumatic	3.14	Yes	1/8 NPT	1/4"
Lift and Rotate	Lift Cylinder	1.75" (44 mm)	3" (76 mm)	Pneumatic	2.40	Yes	1/8 NPT	1/4"
	Rotate Cylinder	1" (25 mm)	N/A	Pneumatic	N/A	Yes	1/8 NPT	1/4"
Corner and Merge	Lift Cylinder (3x each)	1.0625" (27 mm)	0.5" (13 mm)	Pneumatic	0.88	Yes	1/8 NPT	1/4"
Cushion Stop	Stop Retract	1.39" (35 mm)	0.35" (9 mm)	Spring	N/A	No	M5	1/4"
Non-Cushion Stop	Stop Retract	1.39" (35 mm)	0.35" (9 mm)	Spring	N/A	No	M5	1/4"

2200 Precision Move Pallet System Module Spacing

Pallet Stop to Lift & Locate		
Pallet Length L (mm)	Minimum Distance D1	Minimum Distance D2
160	3.23" (82 mm)	12.99" (330 mm)
240	4.80" (122 mm)	12.99" (330 mm)
320	6.38" (162 mm)	12.68" (322 mm)
400	7.95" (202 mm)	15.83" (402 mm)
480	9.53" (242 mm)	18.98" (482 mm)

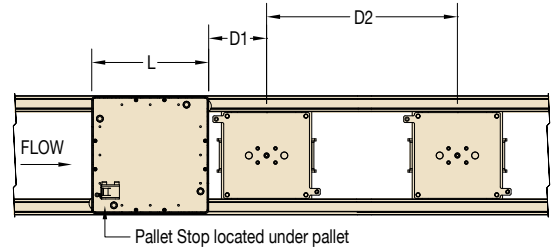

Pallet Stop to Lift & Transfer			
Pallet Length L (mm)	Minimum Distance D1	Minimum Distance D2 Hardstop	Minimum Distance D2 Cushion
160	3.23" (82 mm)	10.35" (263 mm)	12.91" (328 mm)
240	4.80" (122 mm)	13.50" (343 mm)	16.06" (408 mm)
320	6.38" (162 mm)	16.65" (423 mm)	19.21" (488 mm)
400	7.95" (202 mm)	19.80" (503 mm)	22.36" (568 mm)
480	9.53" (242 mm)	22.95" (583 mm)	25.51" (648 mm)

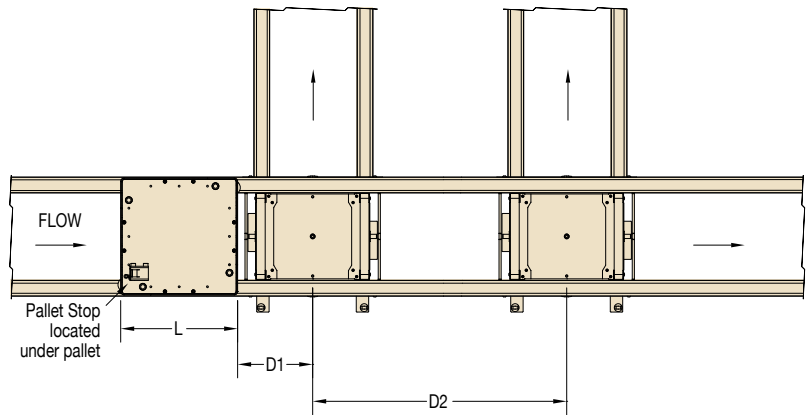

Parallel Conveyors with 90 Degree Corners		
Pallet Width W (mm)	Minimum Parallel Center Line X	Minimum Conveyor Length Y
160	33.94" (862 mm)	27.01" (686 mm)
240	37.09" (942 mm)	27.01" (686 mm)
320	40.24" (1022 mm)	27.01" (686 mm)
400	43.39" (1102 mm)	27.01" (686 mm)
480	46.54" (1182 mm)	27.01" (686 mm)

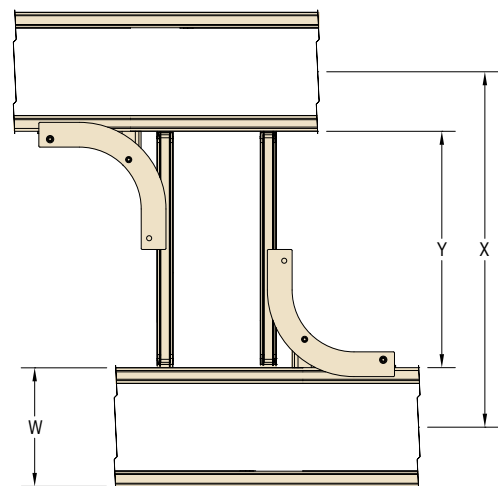

2200 Precision Move Pallet System Module Spacing *Continued*

Parallel Conveyors with Lift & Transfer		
Pallet Width W (mm)	Pallet Center Line X	Conveyor Length Y
160	18.23" (463 mm)	10.83" (275 mm)
240	21.38" (543 mm)	10.83" (275 mm)
320	24.53" (623 mm)	10.83" (275 mm)
400	27.68" (703 mm)	10.83" (275 mm)
480	30.83" (783 mm)	10.83" (275 mm)

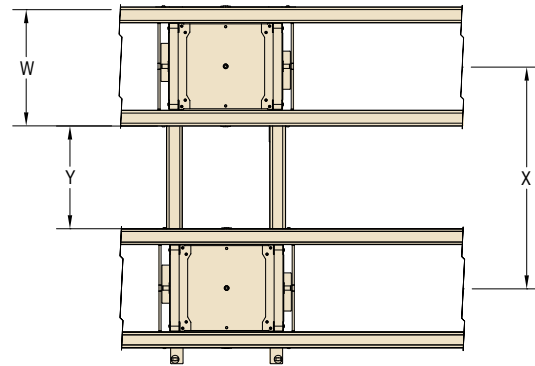

Lift and Locate after 90 Degree Corner or Merge	
Pallet Width W (mm)	Minimum Distance L
160	19.84" (504 mm)
240	22.99" (584 mm)
320	26.14" (664 mm)
400	29.29" (744 mm)
480	32.44" (824 mm)

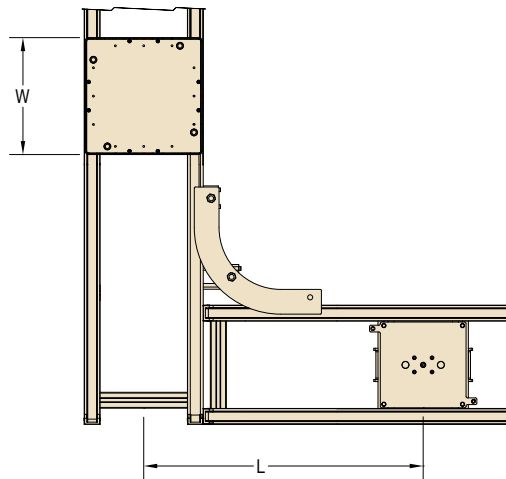

Multiple 90 Degree Corners and Merge	
Pallet Width W (mm)	Minimum Distance X
160	20.24" (514 mm)
240	23.39" (594 mm)
320	26.54" (674 mm)
400	29.69" (754 mm)
480	32.83" (834 mm)

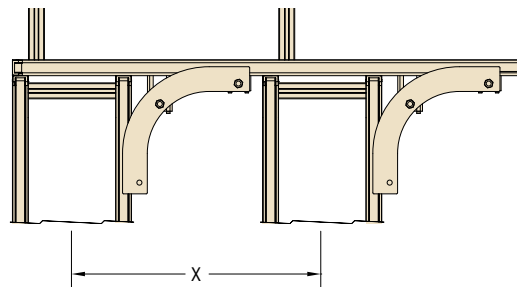

2200 Precision Move Pallet System Module Spacing *Continued*

Heavy Load Corner – 90 Degree		
Pallet Width W (mm)	X	Y
320	41.5" (1054 mm)	29.5" (749 mm)
400	45" (1143 mm)	31.25" (794 mm)
480	48" (1219 mm)	32.75" (832 mm)

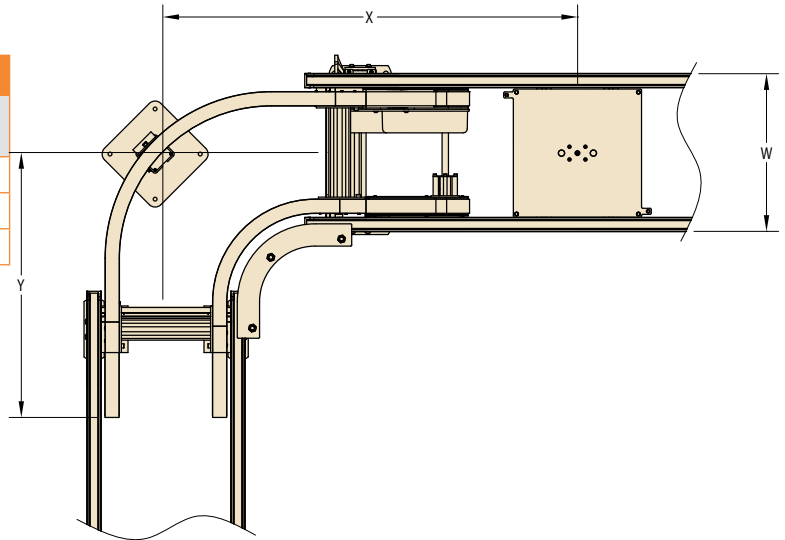

Heavy Load Corner – 180 Degree		
Pallet Width W (mm)	X	Y
320	42" (1067 mm)	30.5" (775 mm)
400	46" (1168 mm)	33.5" (851 mm)
480	47" (1194 mm)	36.75" (933 mm)

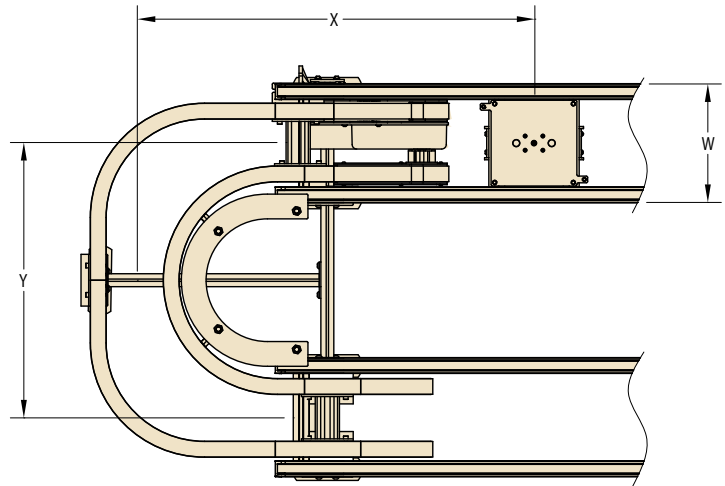

180 Degree Corner		
Pallet Width W (mm)	X	Y
160	18" (457 mm)	12.25" (311 mm)
240	20.5" (521 mm)	15.37" (390 mm)
320	22.5" (572 mm)	18.5" (470 mm)

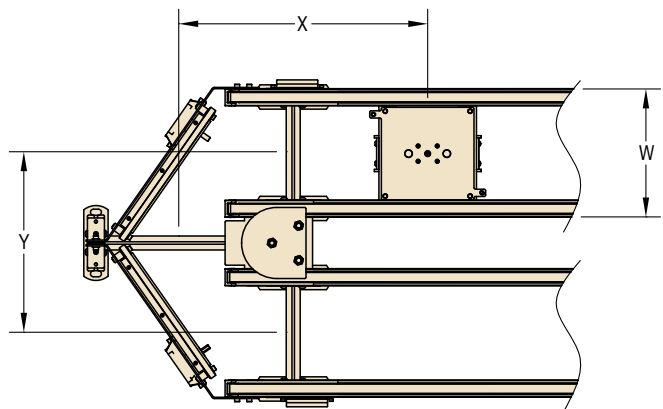

Pallet Plate Details Dimensions

The following details are for standard square pallets only. For other size pallets contact Dorner.

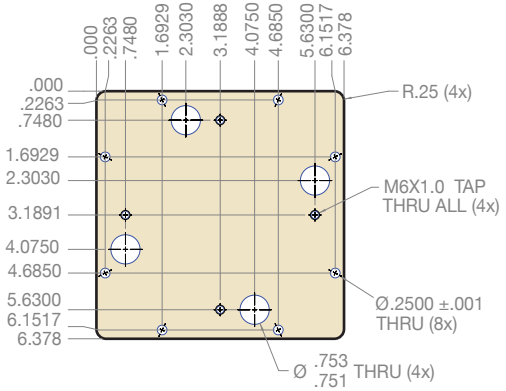

160 x 160

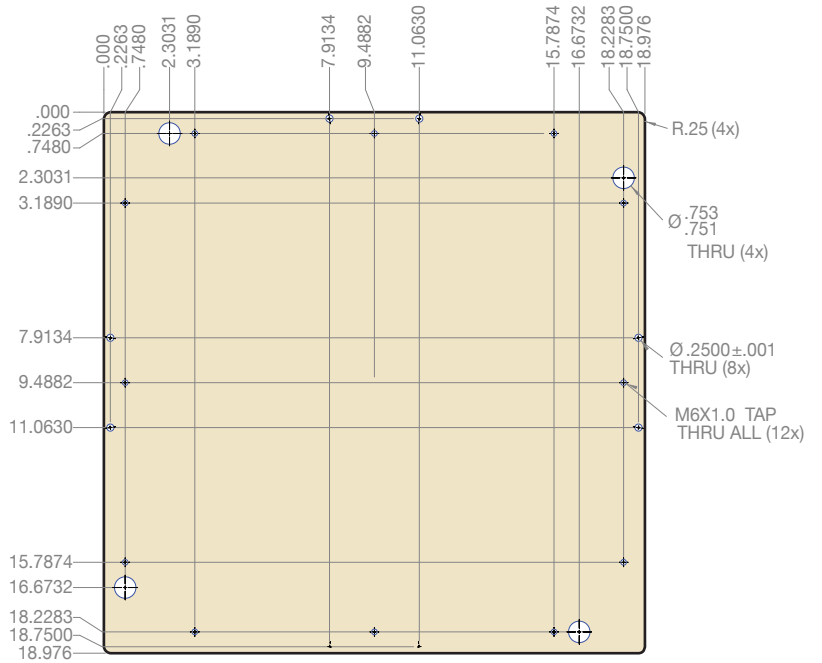

480 x 480

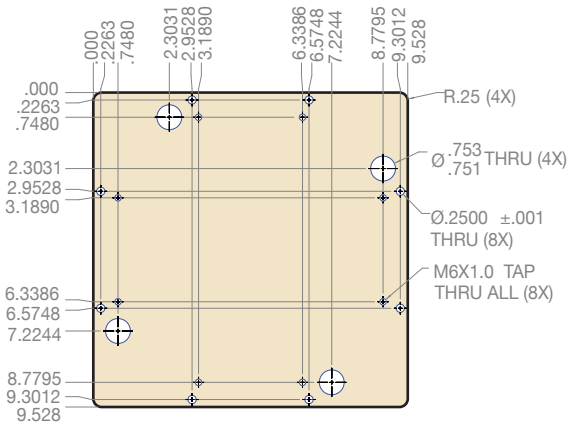

240 x 240

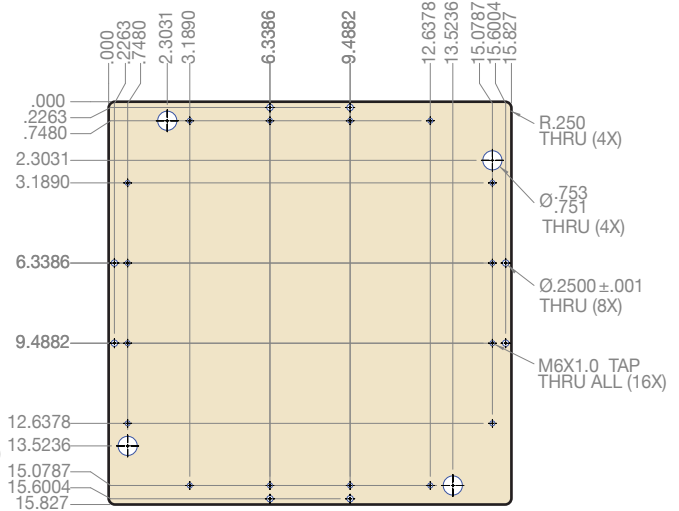

400 x 400

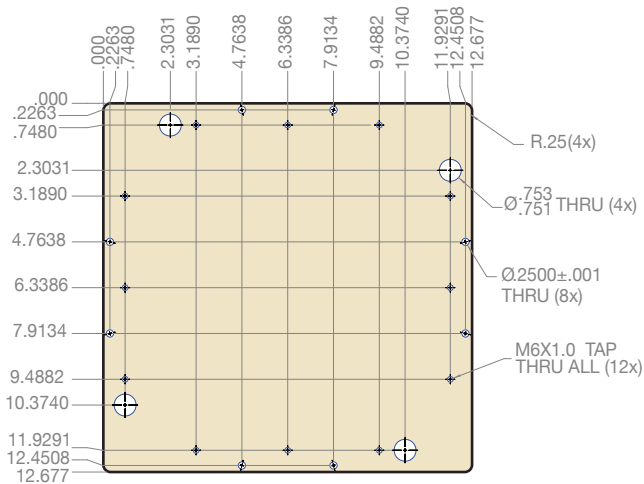

320 x 320

2200 Series Precision Move Pallet Systems are Best for:

- Medium to Large Size Part Movement
- Product Routing and Control
- Product Inspection
- Assembly Automation in:
 - Automotive
 - Electronics
 - Medical
- Life Science Products
- Health and Beauty Products
- Appliance Products

Sizes & Measurements

- Widths: 160, 240, 320, 400, and 480 mm
- Lengths: Up to 24' 7" (7500 mm)

Loads & Speeds

- Conveyor Load Capacity
 - 500 lbs non-accumulating
 - 250 lbs accumulated
- Pallet capacity of 30 to 70 lbs
- Speeds up to 114 ft/min (34 m/min)

Conveyors

- Dual belt conveyors with common drive module
- 25 mm wide 5 mm pitch timing belt conveyor
- Standard or static conductive belting available
- Aluminum extruded frame with universal T-Slot
- Quick belt change without conveyor removal



Pallets

- 160 mm to 480 mm
- Industry compatible sizes and bushing locations
- Static conductive pallet skirt
- Square and rectangular sizes available
- Pallets available as kits or completed assemblies



Modules

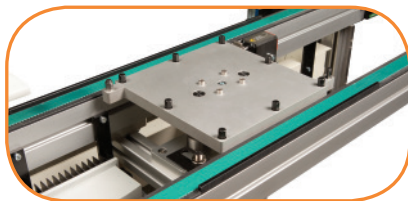

Lift & Locate



Lift & Rotate

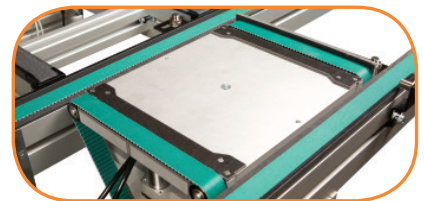

Lift & Transfer

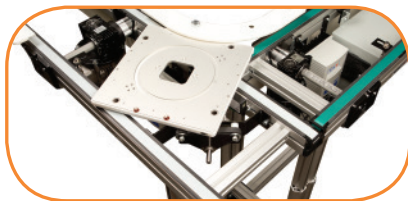

90 Degree Corner

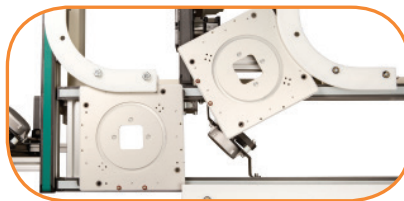

90 Degree Corner & Merge



Cushioned Pallet Stop
(Non-cushioned also available)

At Dorner our mission is to **Transform Conveyor Automation** by providing cutting edge solutions with best-in-class support. It's that commitment and history of proven excellence that has made the Dorner Brand a recognized leader in precision conveyors for over 50 years. With our complete line of customizable stainless steel and aluminum conveyor automation systems, we have the right solution for you!



1X Series

The 1X Series Line is designed for small part handling and transfers where space is a premium.

1X Series Family:

- Flat Belt
- Aluminum Frame
- Widths to 10"
- Loads to 15 lbs
- Speeds up to 80 fpm



2X Series

The 2X Series Line is engineered for small to medium sized parts, precision applications and flexible layouts.

2X Series Family:

- Flat Belt
- Cleated Belt
- Modular Belt
- Precision Move
- SmartFlex®
- Aluminum Frame
- Widths to 24"
- Loads to 200 lbs
- Speeds up to 400 fpm
- Curves
- Z-Frame Elevators



3X Series

The 3X Series Line is designed for medium to heavy sized parts, precision applications, bulk handling and flexible layouts.

3X Series Family:

- Flat Belt
- Cleated Belt
- Modular Belt
- Flexible Chain
- Precision Move
- Aluminum Frame
- Widths to 60"
- Loads to 1000 lbs
- Speeds up to 600 fpm
- Curves
- Z-Frame Elevators

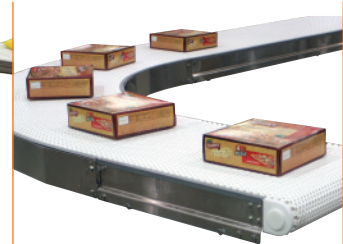

7X Series

The 7X Series Stainless Steel Line is engineered for small to heavy product requiring various levels of sanitary design and flexible layouts.

7X Series Family:

- AquaPruf® + AquaGuard®
- Flat Belt
- Cleated Belt
- Modular Belt
- Flexible Chain
- Vertical Belt Technology
- Stainless Steel Frame
- Widths to 52"
- Loads to 750 lbs
- Speeds up to 400 fpm
- Curves
- Z-Frame Elevators

NEED SOMETHING DIFFERENT?

DORNER'S **ENGINEERED SOLUTIONS GROUP** PROVIDES EXACTLY WHAT YOU NEED FOR YOUR SPECIFIC APPLICATION. FROM MODIFIED STANDARD CONVEYORS TO COMPLETE CUSTOM DESIGNS.

LOOKING FOR AFTER SALE SUPPORT?

DORNER'S **SERVICES TEAM** PROVIDES COMPLETE SUPPORT FROM REPLACEMENT PARTS TO INSTALLATION AND MAINTENANCE SERVICES.



DORNER MFG. CORP.
PO Box 20 • 975 Cottonwood Ave.
Hartland, WI 53029 USA

INSIDE THE USA
TEL: 800.397.8664
FAX: 800.369.2440

OUTSIDE THE USA
TEL: 262.367.7600
FAX: 262.367.5827

www.dorner.com
info@dorner.com

