

Shibaura Machine



VERTICAL ARTICULATED ROBOT

TVL/TV Series



SHIBAURA MACHINE CO., LTD.

TM ROBOTICS (AMERICAS) INC.
755 Greenleaf Avenue, EIK Grove Village, IL 60007, U.S.A.
TEL: [1]-847-709-7308 Mail: info@tmrobotics.com

TM ROBOTICS (EUROPE) LTD.
Unit 2, Bridge Gate Centre, Martinfield,
Welwyn Garden City, Herts AL7 1JG, UK
TEL: [44]-(0)1707-290370 Mail: sales@tmrobotics.co.uk

www.shibaura-machine.co.jp
www.tmrobotics.co.uk
www.tmrobotics.com



Caution

Before operating the industrial robot, read through and completely understand the instruction manuals.

- The contents included in this catalog are subject to change without prior notice to reflect improvements.

Brings overwhelming competitiveness to your production site

VERTICAL ARTICULATED ROBOT **TVL/TV Series**

A vertical articulated robot allows flexible and three-dimensional motion similar to that of a human being.

Based on advanced technologies cultivated with industrial machinery and plenty of expertise gained through a lot of experience of production sites, Shibaura Machine provides high-quality vertical articulated robots for improvement in customer productivity that attain high-speed capability, complete weight saving, and a lot of functionalities, and realize durability and expandability capable of being applied to a wide range of production environments.

Our articulated robots contribute to process automation, labor-saving, and cost reduction in a wide range of the fields including assembly of electronic equipment and inspection/carrying of food and medicinal products.

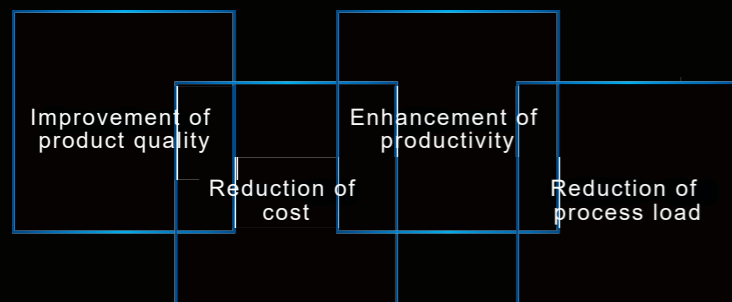

TVL500



TVL700



TV600



TV800



**TV1000
TV1000H**



Application examples of TVL/TV Series

Application examples in our manufacturing sites

Examples of automation in our manufacturing sites using cell production robots

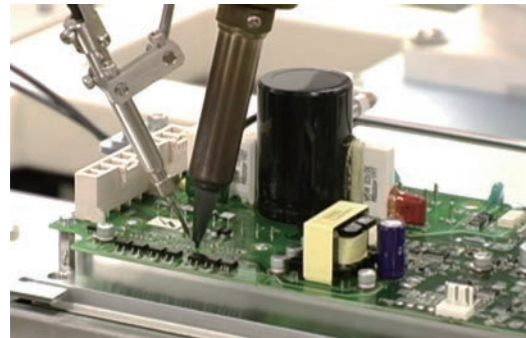

Soldering process

The robot enables stable soldering that produces high quality products efficiently.

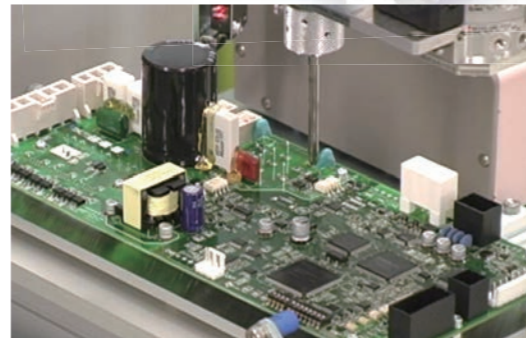

Screw tightening process

Sensorless compliance control technologies is utilized in screw tightening.

Examples of injection molding machine systems

Shibaura Machine has accumulated many automation system examples and considerable understanding of corporation between injection molding machines and robots.



Supply of metal nut parts for insert molding



Thickness measurement and appearance inspection of a 10.1-inch thin light guide plate



Sprue cutting of a CF RTP molded item



Picking up of a C(G)FRTP hybrid molded item

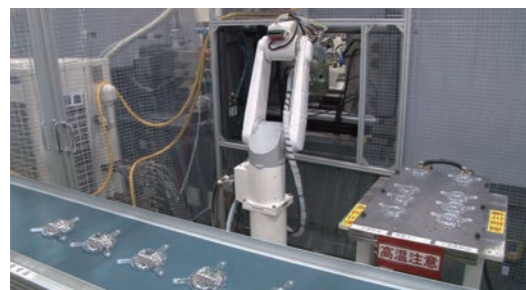

Inserting of a semfinished laminated lens product

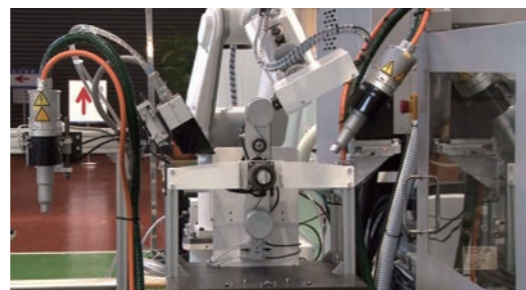

Print decorating in a decoration system

Low-cost robot with top-class performance
Highly cost-effective compact model

Vertical articulated robot TVL Series

The Nikkan Kogyo Shimbun
"45th Machine Design Award
Distinctive Merit Award"



The TVL Series robot achieves high productivity in assembling and transfer processes in small spaces, combining top-class performance with low cost for superior cost effectiveness. A variety of options for convenience and the enhancement of workability, plus suitability for a wide range of work environments, are available.



World-class performance

(standard cycle time of 0.3 seconds level)

Special features

Tap holes

Tool fixture tap holes are provided at four locations on the arm, upper and lower positions. They are useful for fixing external cabling and peripheral devices.



Alternative installations

Tap holes on the side of the base unit allow for the robot to be installed sideways. This reduces the installation space.



1st arm equipped with a T-groove as standard

The T-groove can be used to place tools, cabling and DIN rails in position.



Variety of options

I/O panel options

The I/O panel can be selected from three options. An optional elbow type plug is available on the hand-side connection. Optional

The second arm side



Standard

The second arm top surface

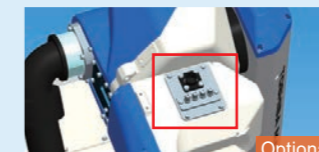

Optional

The third arm side



Optional

Hand side connector elbow type



Optional

Robot controller cable options

In addition to the standard cabling at the back, cabling can be routed through the base. This eliminates the need for installation space at the rear, and increases flexibility relating to the application and the space available.

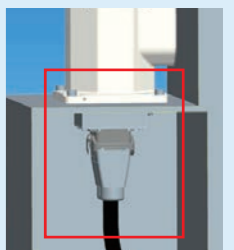

Built-in three-way solenoid valve option

The three-way solenoid valve is built in the robot arm. Optional



Cleanroom option (ISO Class 3)

Compact controller

Controller TSL3100 specifically designed for the vertical articulated robot.

For details, refer to page 11.



World-class performance
(standard cycle time of 0.3 seconds level)

TVL500



The Nikkan Kogyo Shimbun
"45th Machine Design Award
Distinctive Merit Award"



- Arm length 500 mm
- Maximum payload mass 3 kg
- Standard cycle time 0.3 sec level
- IP65 option
- Cleanroom design (optional)
- 3 pcs solenoid valves inside robot arm option

Specifications

Model	TVL500	
Type	Vertically articulated robot	
Number of controlled axis	6 axes	
Arm length	Total length	500 mm
	1st arm	260 mm
	2nd arm	240 mm
	Reach	602 mm
Working envelope	Axis 1 (J1)	±170°
	Axis 2 (J2)	-64~+165°
	Axis 3 (J3)	0~+150°
	Axis 4 (J4)	±190°
	Axis 5 (J5)	±120°
	Axis 6 (J6)	±360°
Maximum speed *1	Axis 1 (J1)	435°/s
	Axis 2 (J2)	348°/s
	Axis 3 (J3)	348°/s
	Axis 4 (J4)	422°/s
	Axis 5 (J5)	422°/s
	Axis 6 (J6)	696°/s
Composite	7.98 m/sec	
Maximum payload mass *1	3 kg (rated: 1 kg)	
	(Downward: 5 kg)	
Standard cycle time *2	0.3 sec level	
Allowable moment of inertia *1	Axis 4, 5	0.15 kg · m ²
	Axis 6	0.2 kg · m ²
Positioning repeatability (X-Y-Z) *3	±0.02 mm (each direction)	
Driving system	AC servo motors	
Hand control signals	4 inputs and 4 outputs	
	(on robot arm HAND I/O panel)	
Power supply	1.5 kVA	
	Mass	28 kg
Robot body	White/blue	
	Color *4	White/blue

*1: Acceleration rates are limited depending on motion patterns, payload mass, and offset value.
*2: Continuous operation of standard cycle motion pattern is not possible beyond the effective load ratio. (Horizontal 300 mm, vertical 25 mm, round-trip, coarse positioning)
*3: When the environment temperature is constant.
*4: Color and surface treatment of the robot body may vary slightly for each production batch. This causes no problem with the product quality.

External view

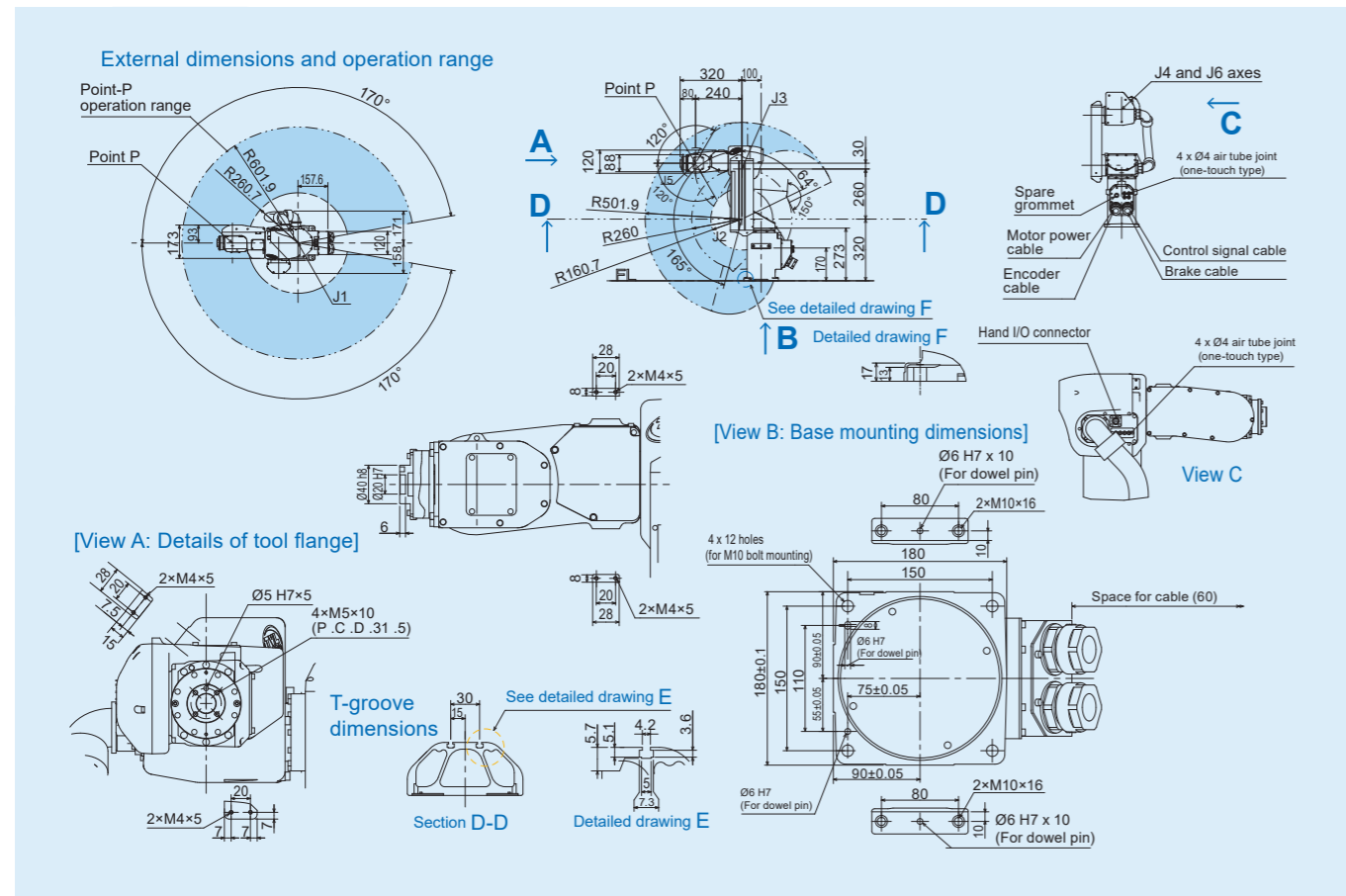

Dealing with a wide range of needs in assembling and transfer processes while realizing high cost effectiveness.

TVL700



The Nikkan Kogyo Shimbun
"45th Machine Design Award
Distinctive Merit Award"



- Arm length 700 mm
- Maximum payload mass 4 kg
- Standard cycle time 0.4 sec level
- IP65 option
- Cleanroom design (optional)
- 3 pcs solenoid valves inside robot arm option

Specifications

Model	TVL700	
Type	Vertically articulated robot	
Number of controlled axis	6 axes	
Arm length	Total length	700 mm
	1st arm	400 mm
	2nd arm	300 mm
	Reach	801 mm
Working envelope	Axis 1 (J1)	±170°
	Axis 2 (J2)	-90~+165°
	Axis 3 (J3)	0~+165°
	Axis 4 (J4)	±190°
	Axis 5 (J5)	±120°
	Axis 6 (J6)	±360°
Maximum speed *1	Axis 1 (J1)	295°/s
	Axis 2 (J2)	270°/s
	Axis 3 (J3)	295°/s
	Axis 4 (J4)	422°/s
	Axis 5 (J5)	422°/s
	Axis 6 (J6)	696°/s
Composite	7.71 m/sec	
Maximum payload mass *1	4 kg (rated: 1 kg)	
	(Downward: 5 kg)	
Standard cycle time *2	0.4 sec level	
Allowable moment of inertia *1	Axis 4, 5	0.15 kg · m ²
	Axis 6	0.2 kg · m ²
Positioning repeatability (X-Y-Z) *3	±0.03 mm (each direction)	
Driving system	AC servo motors	
Hand control signals	4 inputs and 4 outputs	
	(on robot arm HAND I/O panel)	
Power supply	1.5 kVA	
	Mass	31 kg
Robot body	White/blue	
	Color *4	White/blue

*1: Acceleration rates are limited depending on motion patterns, payload mass, and offset value.
*2: Continuous operation of standard cycle motion pattern is not possible beyond the effective load ratio. (Horizontal 300 mm, vertical 25 mm, round-trip, coarse positioning)
*3: When the environment temperature is constant.
*4: Color and surface treatment of the robot body may vary slightly for each production batch. This causes no problem with the product quality.

External view

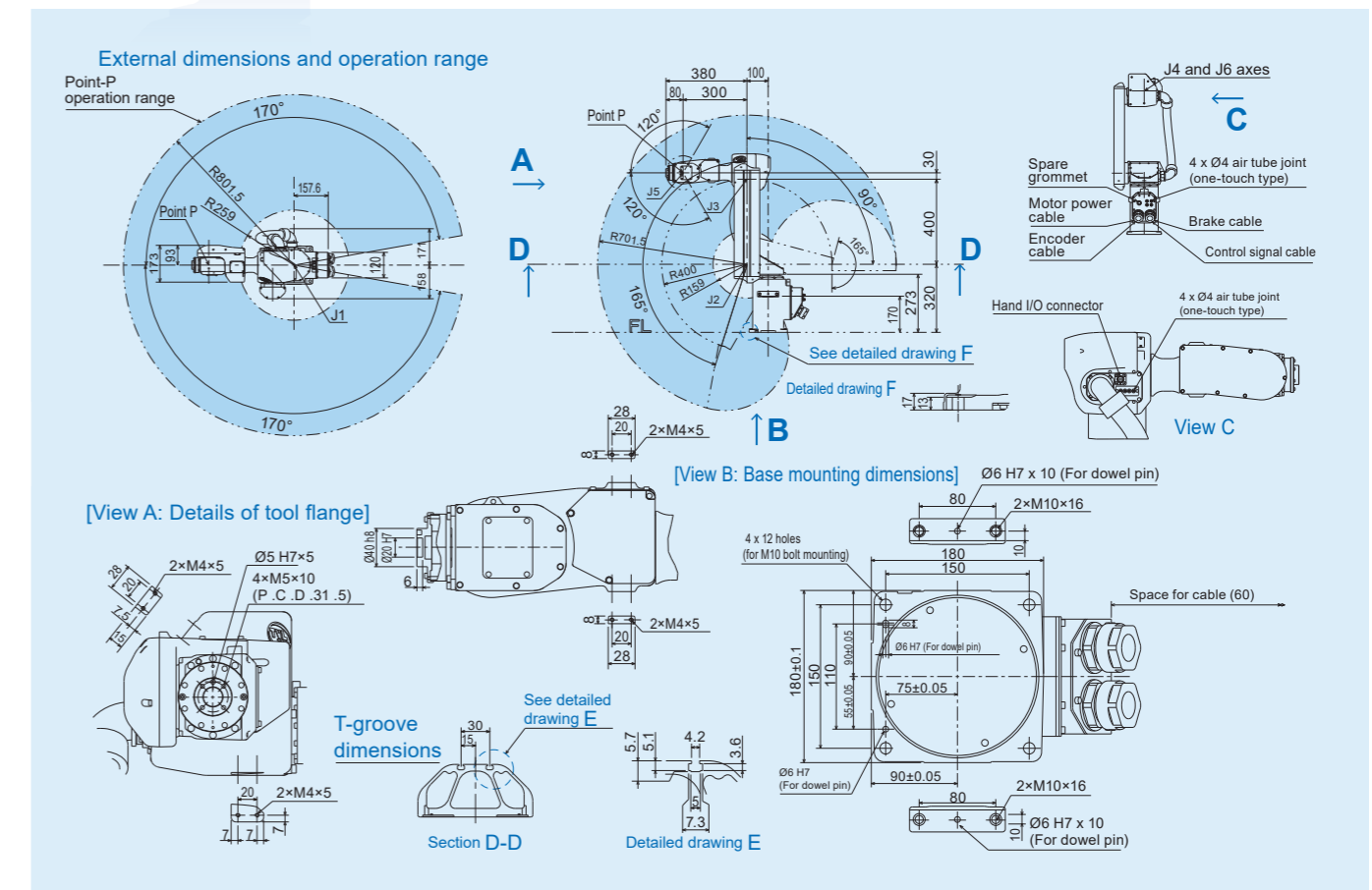

High-end robot with high speed and high rigidity

Vertical articulated robot TV Series

Excellent rigidity, durability, and expandability.
Superior operability with easy-to-use software.
Compliance control using no force sensor.
Elimination of necessity for external sensors allows force control at a low cost.

Excellent rigidity

Excellent durability

Excellent expandability

Capable of inserting and achieving compliance actions without force sensor (sensorless compliance control)

Automation of processes that require force control can be realized without force sensors.

What is the sensorless compliance control?

The TV Series robot attains compliance control without using force sensors. Misalignment is absorbed by the flexible hand with the control that can adjust the force. As a result, stable work processes with less temporary stops can be realized.

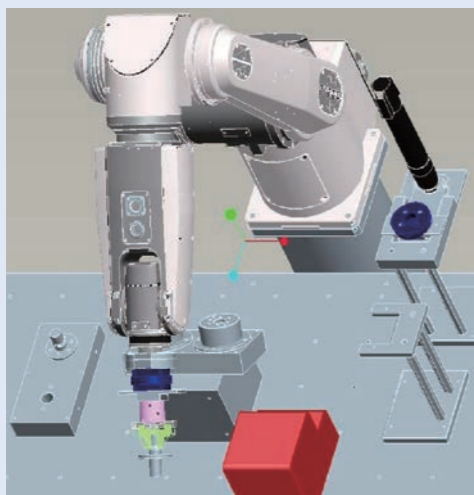

Examples of work process

- 1 Inserting process**
Smooth insertion is realized by loosening horizontal force while pushing vertically with constant insertion force.
- 2 Pin hole searching process**
Even when a hole position cannot be figured out exactly, the robot can find it by turning the wrist while pushing vertically.
- 3 Screwing process**
Synchronization with the screw feed rate is unnecessary. Stable screwing without sticking or failure of a screw can be performed by screwing while pushing vertically with constant force.

High-performance controller

Controller TS3100 specifically designed for the vertical articulated robot.

For details, refer to page 12.



Compact and light-weight robot that can be introduced into production facilities with ease.
Suitable for assembling work such as fitting processes due to the flexible hand control.

TV600



- Arm length 572 mm
- Maximum payload mass 3 kg
- Compact and light-weight
- User friendly software

Specifications

Model	TV600	
Type	Vertically articulated robot	
Number of controlled axis	6 axes	
Arm length	Total length	572 mm
	1st arm	270 mm
	2nd arm	302 mm
	Reach	580 mm
Working envelope	Axis 1 (J1)	±165°
	Axis 2 (J2)	±110°
	Axis 3 (J3)	0→+160°
	Axis 4 (J4)	±160°
	Axis 5 (J5)	±120°
	Axis 6 (J6)	±400°
Maximum speed ^{*1}	Axis 1 (J1)	250°/s
	Axis 2 (J2)	250°/s
	Axis 3 (J3)	250°/s
	Axis 4 (J4)	320°/s
	Axis 5 (J5)	320°/s
	Axis 6 (J6)	420°/s
Maximum payload mass ^{*1}	3 kg (rated: 1 kg)	
Standard cycle time ^{*2}	0.5 sec level	
Allowable moment of inertia ^{*1}	Axis 4, 5	0.02 kg · m ²
	Axis 6	0.015 kg · m ²
Positioning repeatability (X-Y-Z) ^{*3}	±0.02 mm (each direction)	
Driving system	AC servo motors	
Hand control signals	4 inputs and 4 outputs	
Power supply	1.0 kVA	
Robot body	Mass	25 kg
	Color ^{*4}	White

^{*1}: Acceleration rates are limited depending on motion patterns, payload mass, and offset value.
^{*2}: Continuous operation of standard cycle motion pattern is not possible beyond the effective load ratio. (Horizontal 300 mm, vertical 25 mm, round-trip, coarse positioning)
^{*3}: When the environment temperature is constant.
^{*4}: Color and surface treatment of the robot body may vary slightly for each production batch. This causes no problem with the product quality.

External view

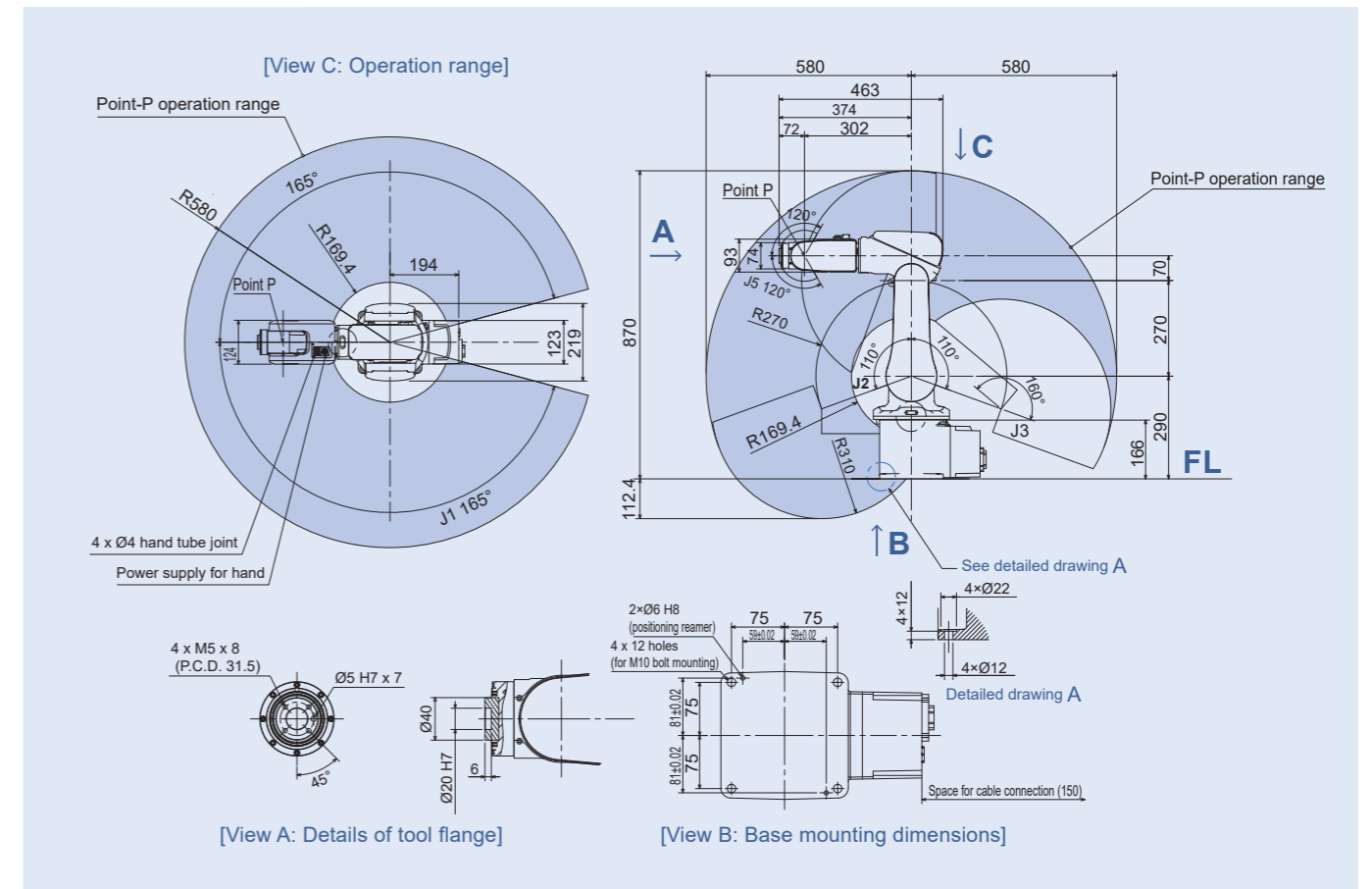

Plenty of options available for various environments.
Applicable to a wide range of needs including production lines and assembly processes

TV800



- Arm length 800 mm
- Maximum payload mass 5 kg
- Standard cycle time 0.4 sec level

Optional

- Dust and drip proof (IP65)
- Cleanroom design
- Safety category 3
- Ceiling mount
- 3 pcs solenoid valves inside robot arm

Specifications

Model	TV800	
Type	Vertically articulated robot	
Number of controlled axis	6 axes	
Arm length	Total length	800 mm
	1st arm	380 mm
	2nd arm	420 mm
	Reach	892 mm
Working envelope	Axis 1 (J1)	±170°
	Axis 2 (J2)	-100~+150°
	Axis 3 (J3)	-127~+167°
	Axis 4 (J4)	±190°
	Axis 5 (J5)	±120°
	Axis 6 (J6)	±360°
Maximum speed ^{*1}	Axis 1 (J1)	237°/s
	Axis 2 (J2)	240°/s
	Axis 3 (J3)	288°/s
	Axis 4 (J4)	350.5°/s
	Axis 5 (J5)	484°/s
	Axis 6 (J6)	576°/s
Composite	8.06 m/sec	
Maximum payload mass ^{*1}	5 kg (rated: 2 kg)	
Standard cycle time ^{*2}	0.4 sec level	
Allowable moment of inertia ^{*1}	Axis 4, 5	0.3 kg·m ²
	Axis 6	0.05 kg·m ²
Positioning repeatability (X-Y-Z) ^{*3}	±0.02 mm (each direction)	
Driving system	AC servo motors	
Hand control signals	8 inputs and 2 outputs (on robot arm HAND I/O panel)	
	8 inputs and 8 outputs (on controller front panel)	
Power supply	2.5 kVA	
Robot body	Mass	45 kg
	Color ^{*4}	White/Light gray

^{*1}: Acceleration rates are limited depending on motion patterns, payload mass, and offset value.
^{*2}: Continuous operation of standard cycle motion pattern is not possible beyond the effective load ratio.
(Horizontal 300 mm, vertical 25 mm, round-trip, coarse positioning)
^{*3}: When the environment temperature is constant.
^{*4}: Color and surface treatment of the robot body may vary slightly for each production batch.
This causes no problem with the product quality.

External view

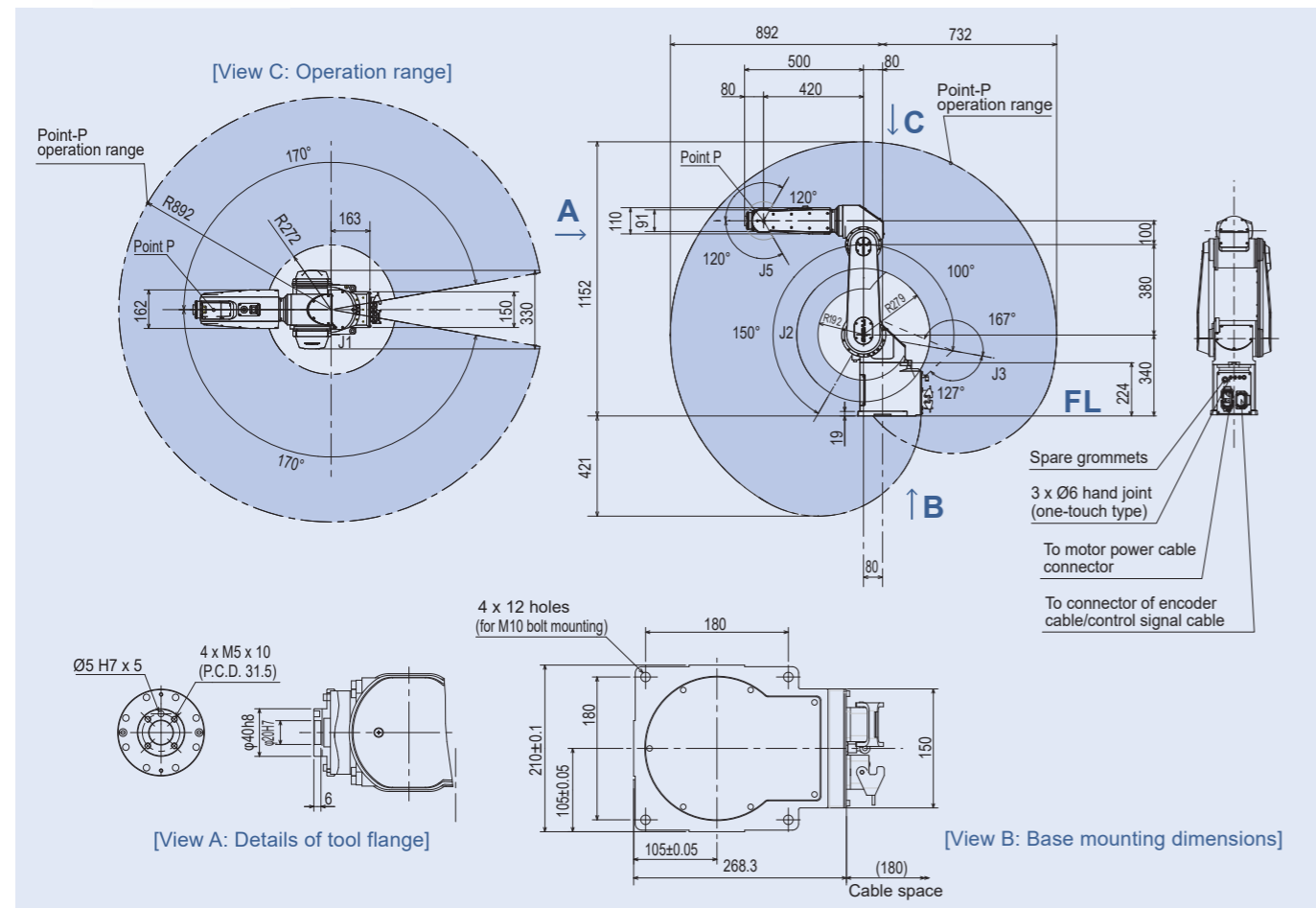

Plenty of options available for various environments.
Lightest robot in class.

TV1000/TV1000H



- <TV1000>
- Arm length 1,000 mm
 - Maximum payload mass 5 kg
 - Standard cycle time 0.6 sec level

Optional

- Payload mass 10 kg (TV1000H)
- Dust and water proof (IP67)
- * only for wrist of TV1000H
- Dust and drip proof (IP65)
- Cleanroom design
- Safety category 3
- Ceiling mount
- 3 pcs solenoid valves inside robot arm

Specifications

Model	TV1000	TV1000H	
Type	Vertically articulated robot		
Number of controlled axis	6 axes		
Arm length	Total length	1,000 mm	
	1st arm	480 mm	
	2nd arm	520 mm	
	Reach	1,090 mm	
Working envelope	Axis 1 (J1)	±170°	
	Axis 2 (J2)	-100~+150°	
	Axis 3 (J3)	-127~+167°	
	Axis 4 (J4)	±190°	
	Axis 5 (J5)	±120°	
	Axis 6 (J6)	±360°	
Maximum speed ^{*1}	Axis 1 (J1)	237°/s	
	Axis 2 (J2)	240°/s	
	Axis 3 (J3)	288°/s	
	Axis 4 (J4)	350.5°/s	
	Axis 5 (J5)	484°/s	
	Axis 6 (J6)	576°/s	
Composite	9.61 m/sec	7.46 m/sec	
Maximum payload mass ^{*1}	5 kg (rated: 2 kg)	10 kg (rated: 2 kg)	
Standard cycle time ^{*2}	0.6 sec level	0.9 sec level	
Allowable moment of inertia ^{*1}	Axis 4, 5	0.3 kg·m ²	
	Axis 6	0.05 kg·m ²	
Positioning repeatability (X-Y-Z) ^{*3}	±0.03 mm (each direction)		
Driving system	AC servo motors		
Hand control signals	8 inputs and 2 outputs (on robot arm HAND I/O panel)		
	8 inputs and 8 outputs (on controller front panel)		
Power supply	2.5 kVA		
Robot body	Mass	47 kg	
	Color ^{*4}	White/Light gray	

^{*1}: Acceleration rates are limited depending on motion patterns, payload mass, and offset value.
^{*2}: Continuous operation of standard cycle motion pattern is not possible beyond the effective load ratio.
(Horizontal 300 mm, vertical 25 mm, round-trip, coarse positioning)
^{*3}: When the environment temperature is constant.
^{*4}: Color and surface treatment of the robot body may vary slightly for each production batch.
This causes no problem with the product quality.

External view

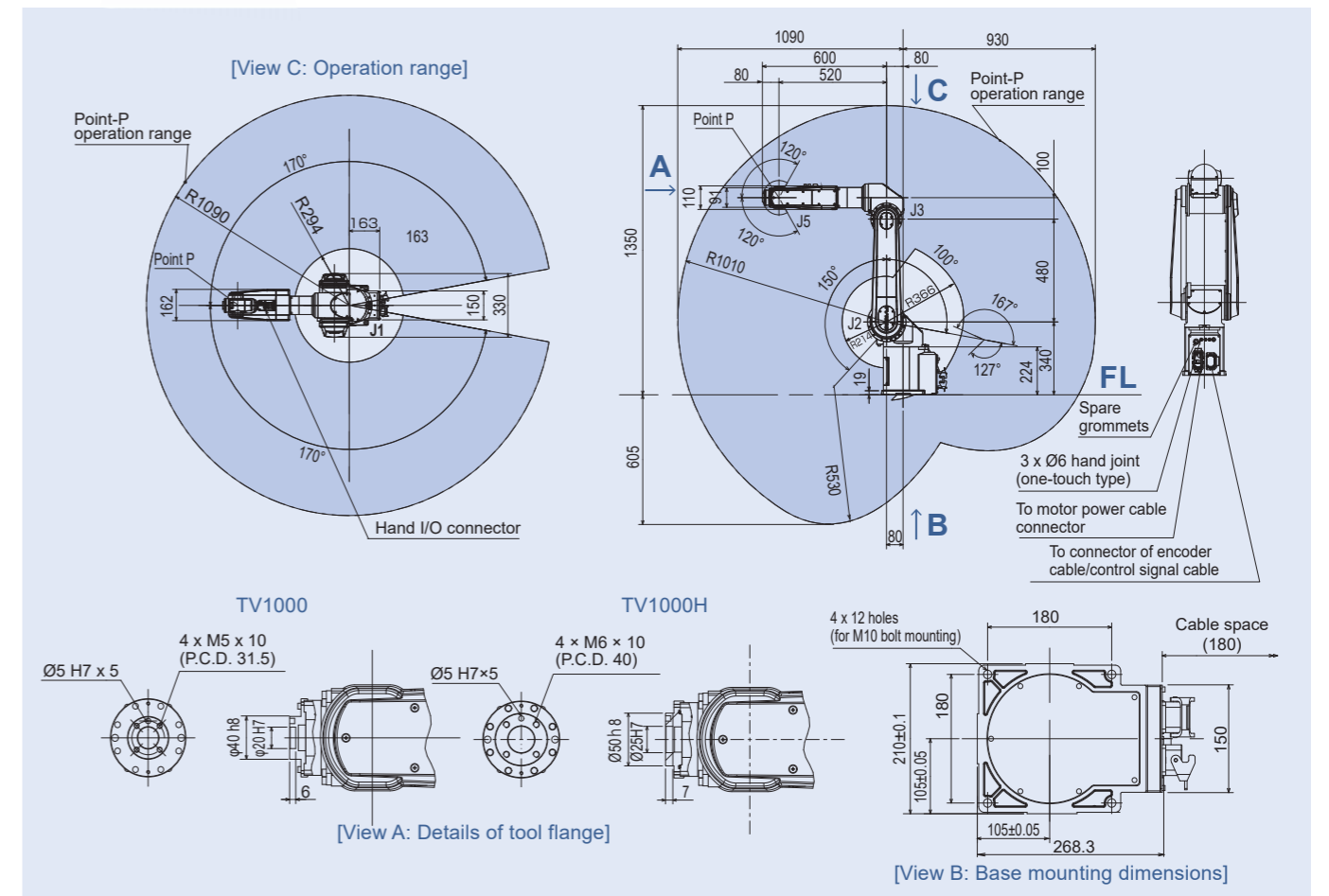

Controllers and teach pendants specifically designed for the vertical articulated robot

For TVL Series

TSL3100

Cost effective compact controller



For TVL Series

TSL3100E

Low-cost and compact CE compliant controller



CE compliant

For all TVL Series robots

Teach pendant **Optional**

TP1000-6ax

Standard teach pendant

TP3000

Teach pendant equipped with graphic operation keys



TP1000-6ax

TP3000

Specifications

Model	TSL3100	TSL3100E
Number of controlled axes	Maximum 6 axes	Maximum 6 axes
Motion modes	PTP, CP (Continuous Path; Linear, Circular), Short-Cut	PTP, CP (Continuous Path; Linear, Circular), Short-Cut
Storage capacity	Approx. Total: 6,400 point + 12,800 steps 1 program: 2,000 point + 3,000 steps	Approx. Total: 12,800 point + 25,600 steps 1 program: 2,000 point + 3,000 steps
Number of registerable programs	Maximum 256	Maximum 256
Programming language	SCOL (similar to BASIC)	SCOL (similar to BASIC)
Teach pendant (optional)	Teach pendants TP3000 and TP1000-6ax (Program can also be written on PC)	Teach pendants TP3000 and TP1000-6ax (Program can also be written on PC)
Extended I/O signals	8 inputs / 8 outputs	8 inputs / 8 outputs
External operation signals	Input: cycle operation mode, start, stop, etc. (13 signals) Output: Servo ON, emergency stop, etc. (11 signals)	Input: cycle operation mode, start, stop, etc. (13 signals) Output: External mode, automatic operation, etc. (9 signals)
Communication ports	RS232C: 2 ports, Ethernet*: 1 port, USB	RS232C: 2 ports, Ethernet*: 1 port, USB
Other functions	Interruptive functions, self-diagnosis, I/O control and communications during motion, coordinate calculations, built-in PLC, etc.	Interruptive functions, self-diagnosis, I/O control and communications during motion, coordinate calculations, built-in PLC, etc.
Power supply	Single phase AC190 V to 240 V, 50/60 Hz	Single phase AC190 V to 240 V, 50/60 Hz
Outer dimensions and mass	220(W) x 266(H) x 304(D) [mm], 9 kg (including rubber feet)	320(W) x 266(H) x 304(D) [mm], 13 kg (including rubber feet)
PC software for programming support (option)	TSAssist: Program editor, teaching, remote operation, etc.	TSAssist: Program editor, teaching, remote operation, etc.
Options	I/O extension, I/O cable, Field-network (CC-Link, DeviceNet, PROFIBUS, EtherNet/IP, EtherCAT, PROFINET)*1, Additional axis	I/O extension, I/O cable, Field-network (CC-Link, DeviceNet, PROFIBUS, EtherNet/IP, EtherCAT, PROFINET)*1, Conveyor synchronization, Trigger input, Additional axis

*1 Ethernet is a registered trademark of XEROX Corp. in the U.S.A. CC-Link is a registered trademark of CC-Link Partner Association. DeviceNet and EtherNet/IP are registered trademarks of ODVA. PROFIBUS and PROFINET are registered trademarks of PROFIBUS User Organization. EtherCAT® is registered trademark and patented technology, licensed by Beckhoff Automation GmbH, Germany.

External view

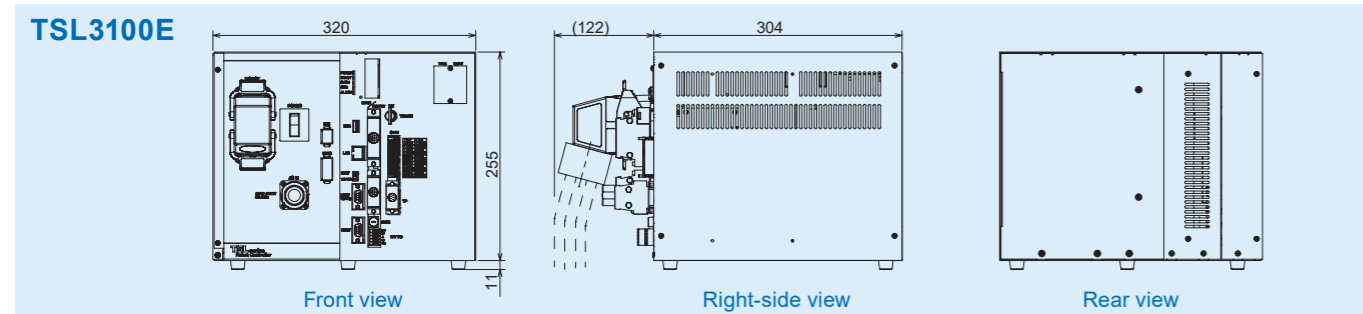
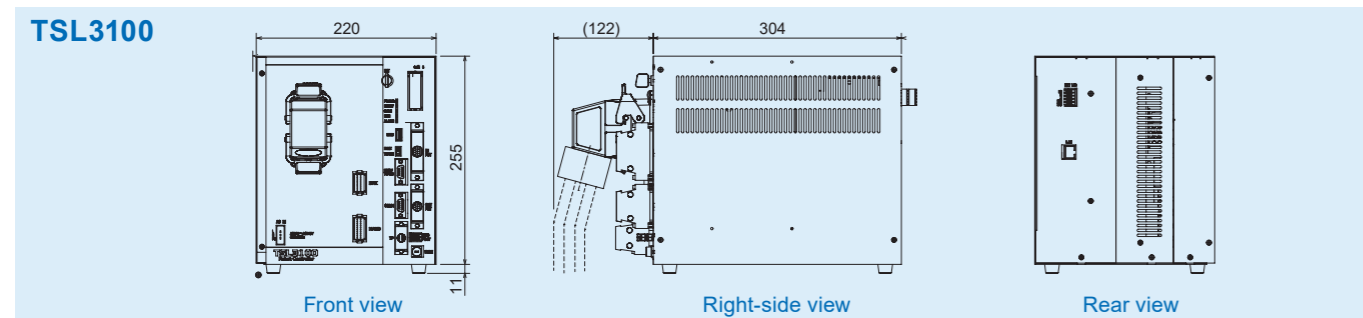

For TV600

TS3100V2

Controller for vertical articulated robot TV600 with up to six axes simultaneous control.



Teach pendant **Optional**

TP1000-6ax

Standard teach pendant

TP3000

Teach pendant equipped with graphic operation keys



TP1000-6ax

TP3000

Specifications

Model	TS3100V2	TS3100
Number of controlled axes	Maximum 6 axes	Maximum 6 axes
Motion modes	PTP, CP (Continuous Path; Linear, Circular), Short-Cut	PTP, CP (Continuous Path; Linear, Circular), Short-Cut
Storage capacity	Approx. Total: 12,800 point + 25,600 steps 1 program: 2,000 point + 3,000 steps	Approx. Total: 12,800 point + 25,600 steps 1 program: 2,000 point + 3,000 steps
Number of registerable programs	Maximum 256	Maximum 256
Programming language	SCOL (similar to BASIC)	SCOL (similar to BASIC)
Teach pendant (optional)	Teach pendants TP3000 and TP1000-6ax (Program can also be written on PC)	Teach pendants TP3000 and TP1000-6ax (Program can also be written on PC)
Extended I/O signals	32 inputs / 32 outputs	32 inputs / 32 outputs
External operation signals	Input: program selection, start, stop, program reset, etc. (13 signals) Output: Servo ON, ready for operation, failure, cycle stop, etc. (9 signals)	Input: cycle operation mode, start, stop, reset, etc. (13 signals) Output: Servo ON, ready for operation, failure, etc. (9 signals)
Communication ports	RRS232C: 3 ports, Ethernet*: 1 port, USB	RS232C: 3 ports, Ethernet*: 1 port, USB
Other functions	Interruptive functions, self-diagnosis, I/O control and communications during motion, coordinate calculations, built-in PLC, etc.	Interruptive functions, self-diagnosis, I/O control and communications during motion, coordinate calculations, built-in PLC, etc.
Power supply	Single phase AC200 V to 240 V, 50/60 Hz	Single phase AC200 V to 240 V, 50/60 Hz
Outer dimensions and mass	420(W) x 241(H) x 298(D) [mm], approximately 17 kg (including rubber feet)	420(W) x 241(H) x 298(D) [mm], approximately 17 kg (including rubber feet)
PC software for programming support (option)	TSAssist: Program editor, teaching, remote operation, etc.	TSAssist: Program editor, teaching, remote operation, etc.
Options	I/O extension, I/O cable, Field-network (CC-Link, DeviceNet, PROFIBUS, EtherNet/IP, EtherCAT, PROFINET)*1, Additional axis, CE compliant*2	I/O extension, I/O cable, Field-network (CC-Link, DeviceNet, PROFIBUS, EtherNet/IP, EtherCAT, PROFINET)*1, Additional axis, CE compliant*2

*1 Ethernet is a registered trademark of XEROX Corp. in the U.S.A. CC-Link is a registered trademark of CC-Link Partner Association. DeviceNet and EtherNet/IP are registered trademarks of ODVA. PROFIBUS and PROFINET are registered trademarks of PROFIBUS User Organization. EtherCAT® is registered trademark and patented technology, licensed by Beckhoff Automation GmbH, Germany.

*2 Category 3 safety circuit unit TS3SFB is necessary for CE compliance. Also, it is necessary to implement safety systems.

External view

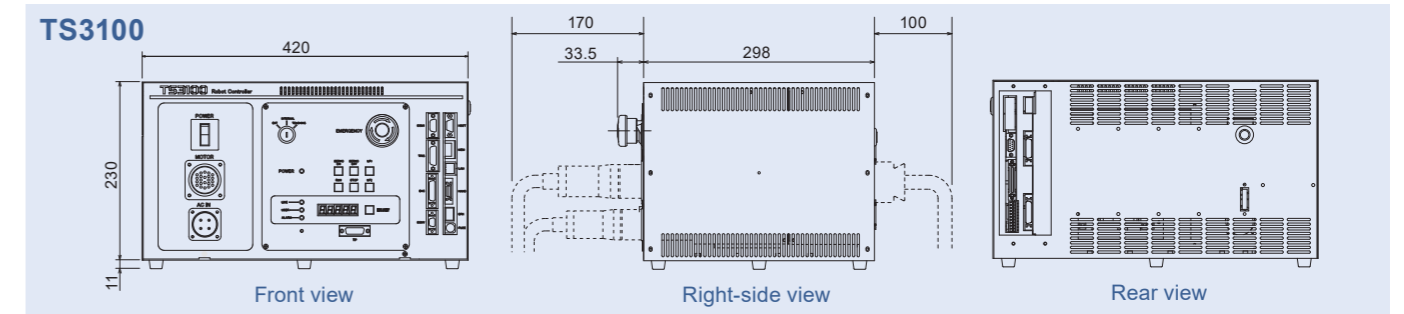
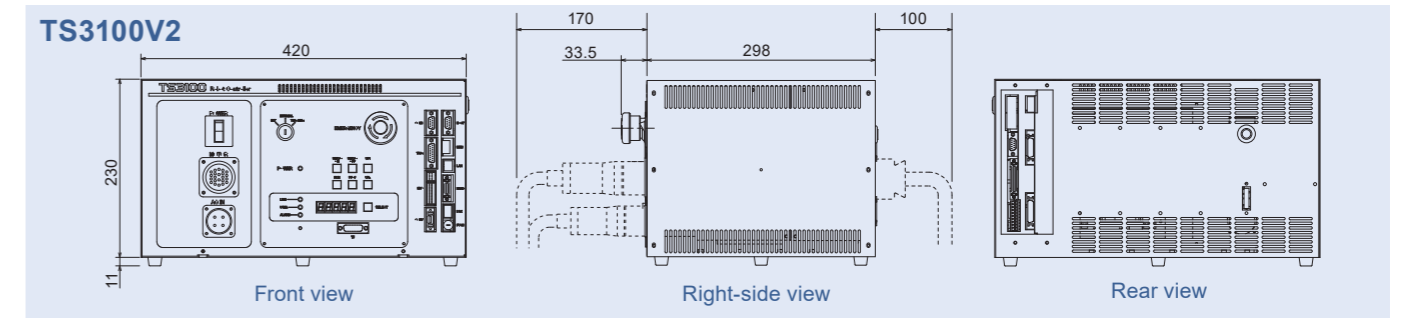

Various functions to support the operation

Options and functions that maximize the robot performance and PC software for efficient robot system building.

Support for Sample Projects

Shibaura Machine × **Pro-face**
for the best interface

Sample Projects are a collaborative system between Shibaura Machine Co., Ltd. and Digital Electronics Corporation. They enable users to check the status of the robot on the touch panel display device.

[Features and Advantages]

- When an error occurs in the robot, the error information or details can be checked on the Alarm Monitor Screen (see the below figure).
- Additionally, various other screens for functions including Robot I/O Monitor, Current Position Monitor, I/O Time Chart and Connected Device Data Transfer are provided.
- The above robot screens can be downloaded from the website of Digital Electronics Corporation free of charge. There is no need to create these screens and they can be used immediately after product purchase.

<http://www.pro-face.com/otasuke/download/sample/manufactures.html>

- The status of the robot can be checked even by people who cannot operate the teach pendant.
- Because the information about both the robot and the system is displayed on the same display device, troubleshooting is much easier.

*For product information about the touch panel that is compatible with this system, please inquire for details.
http://www.pro-face.com/otasuke/sample/detail/common/connection_robot_con_ts_e.html

Built-In PLC

The robot controller has a built-in PLC (TCmini). Input and output signals can be controlled by a ladder program, independent from robot motions.

[Features and Advantages]

- TCmini controls input/output signals of standard I/O, extension I/O and touch-sensitive panel by a ladder program and exchanges data with the robot program.
- By changing the ladder program, system I/O signals can be used as standard I/O signals, and system I/O signals can be assigned as expansion I/O signals and field network I/O signals.
- Flexible system design and control of peripheral equipment are possible without the added cost of an outside host PLC.
- Creation, monitoring and debugging of a ladder program are possible with powerful programming support software "TC-WORX" (optional).
- The scan time is 5ms per 1 K-Word (guideline for TSL3100). Connection is possible with various programmable controllers and display units etc.

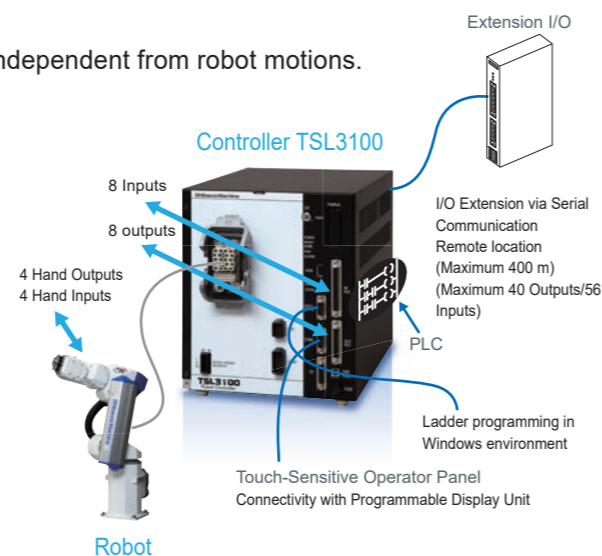

Field Network

Various field network protocols are supported.

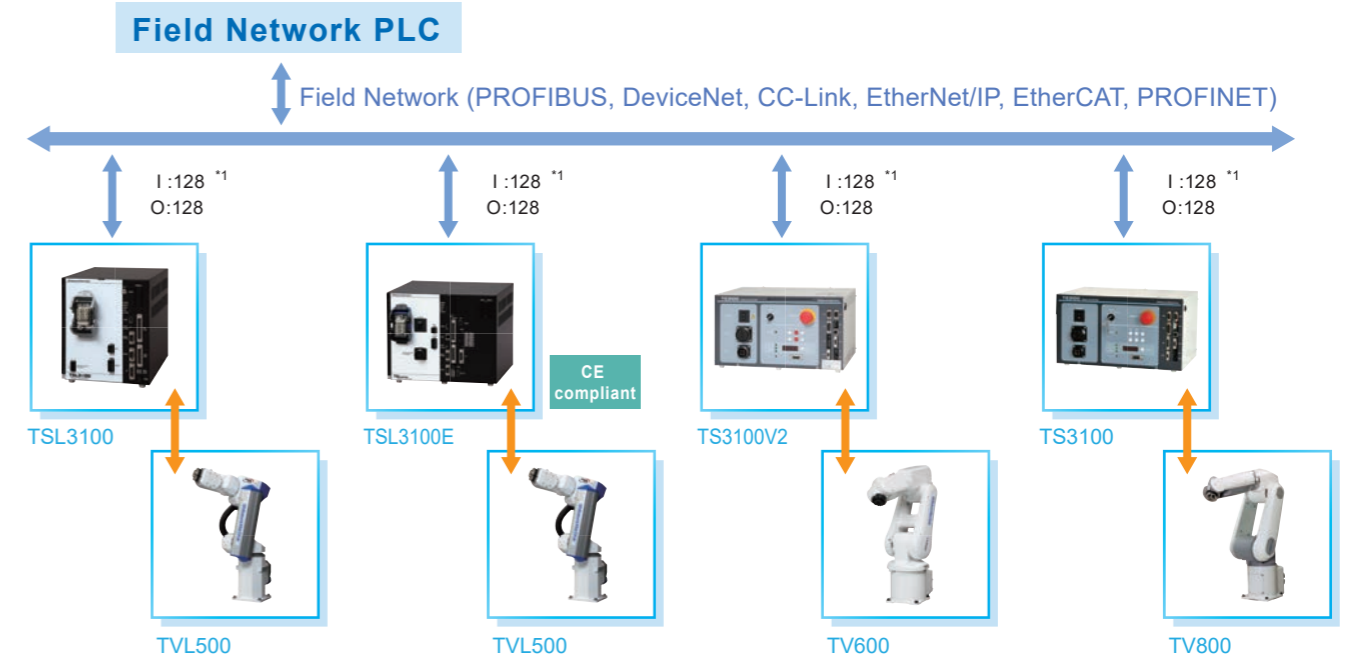

*1: I:126 and O:126 for CC-Link

Robot Programming Assist Tool

TSAssist
Robot Programming Assist Tool

POWERFUL ASSISTANCE TO ALL PHASES OF AUTOMATION FACILITIES, FROM PLANNING, INSTALLATION TO ENHANCEMENT

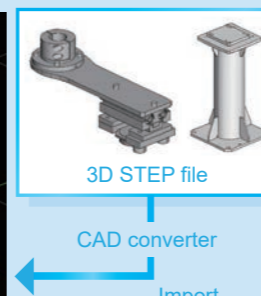
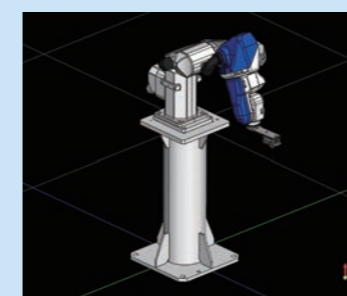

CAD converter
Import

1 High Performance 3D Simulation

Accurate simulation with interference check, locus display, timer (cycle time measurement), placing simple workpieces and model shapes, loading 3D CAD data, saving 3D simulation to a video file, and multi-angle view. These functions enable highly-accurate and a high-quality estimation of robot-automation processes. From simple outline simulation to "get the picture" to accurate simulation closer to actual machine implementation, TSAssist powerfully assists all phases of robot-automation system life cycle, from initial "sketch," planning, proposal, designing and installation, to improvement and re-purposing of existing facilities.

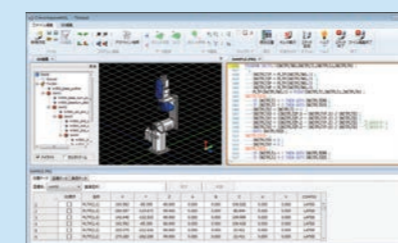

2 Highly Functional Program Editor

Robot language input support (keyword suggestions), Outline display, Split display. Point data (taught position information) editor with, sort, search, filter functions. And in 3D Editor Mode, robot can be guided by mouse dragging and by clicking on object model surface. No complex position calculation is necessary. With these functions, programming can be done efficiently and with minimum mistakes.



3 Easy Operation

Easy-to-understand, intuitive screen design, ribbon interface, window-dock function for customize-able operator panels. Beginners will find it easy to understand and can quickly learn robot programming skills. For experienced robot users, TSAssist helps making robot programs efficiently by customization.