

# ProFeeder



**EasyRobotics**  
- we move your parts

# ProFeeder

- Makes it simple to get started with robot automation.

ProFeeder from EasyRobotics is a compact modular robot cell, prepared for the installation of a robot.

The ProFeeder modular system can be expanded in 3 steps, from production automation of small series that can be upgraded, to full automation of large production series.

The expansion and investment is made in accordance with your production needs.

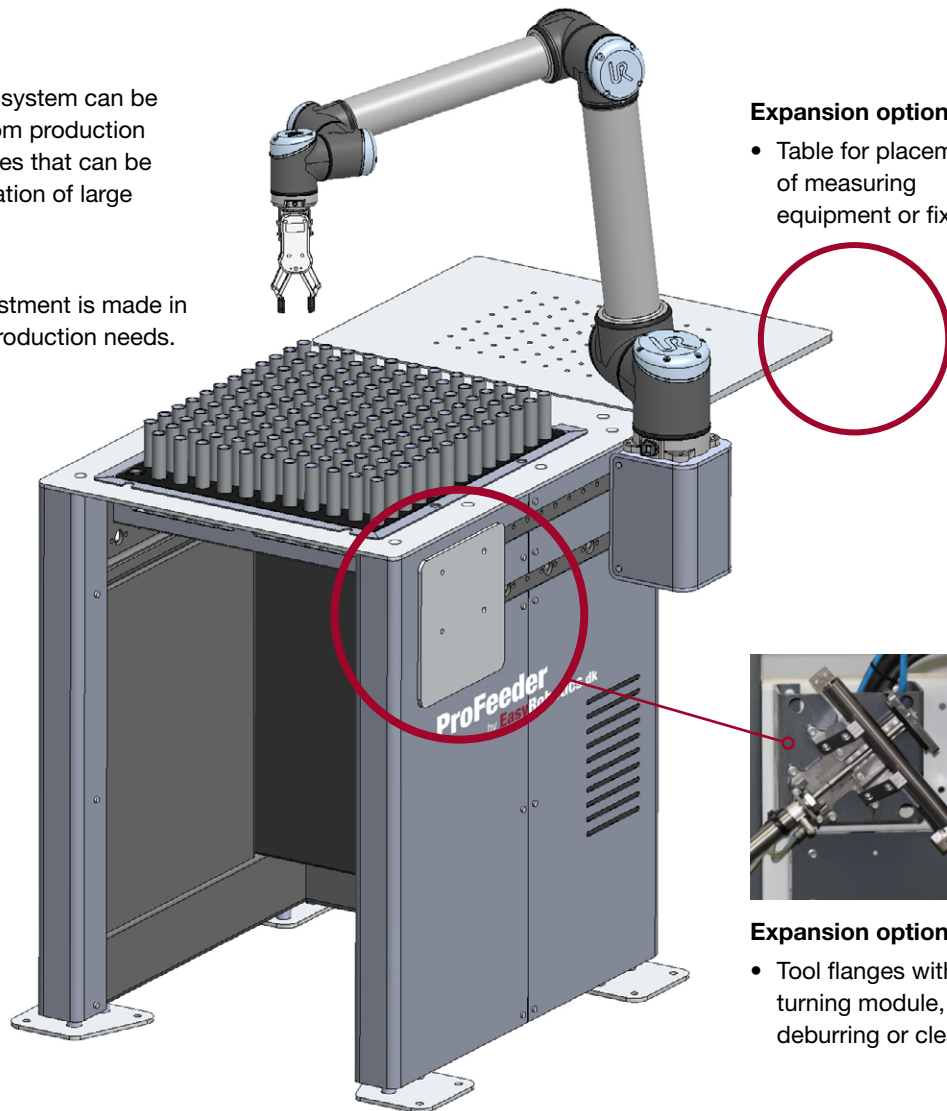

## Expansion options

- Table for placement of measuring equipment or fixtures.

## Expansion options

- Tool flanges with turning module, deburring or cleaning.

# 1

## ProFeeder Light

1 parts tray, the basic module is suitable for small series production.

# 2

## ProFeeder

2 parts trays, 2 movers and automatic centring of parts tray. Suitable for small and medium series production.

# 3

## ProFeeder Multi

4 parts trays, 2 movers and 1 automated lift module. Suitable for series production in fully automated 4-shift operations.

# ProFeeder Light

The ProFeeder Light robot cell consists of a basic module with 1 flexible manual removable parts tray designed for handling all types of parts.

## ProFeeder is suitable for production of small series.

- The robot arm can be moved around on all 3 sides.
- The robot cell can be used with most CNC machines.
- Can handle parts of up to 10 kg.

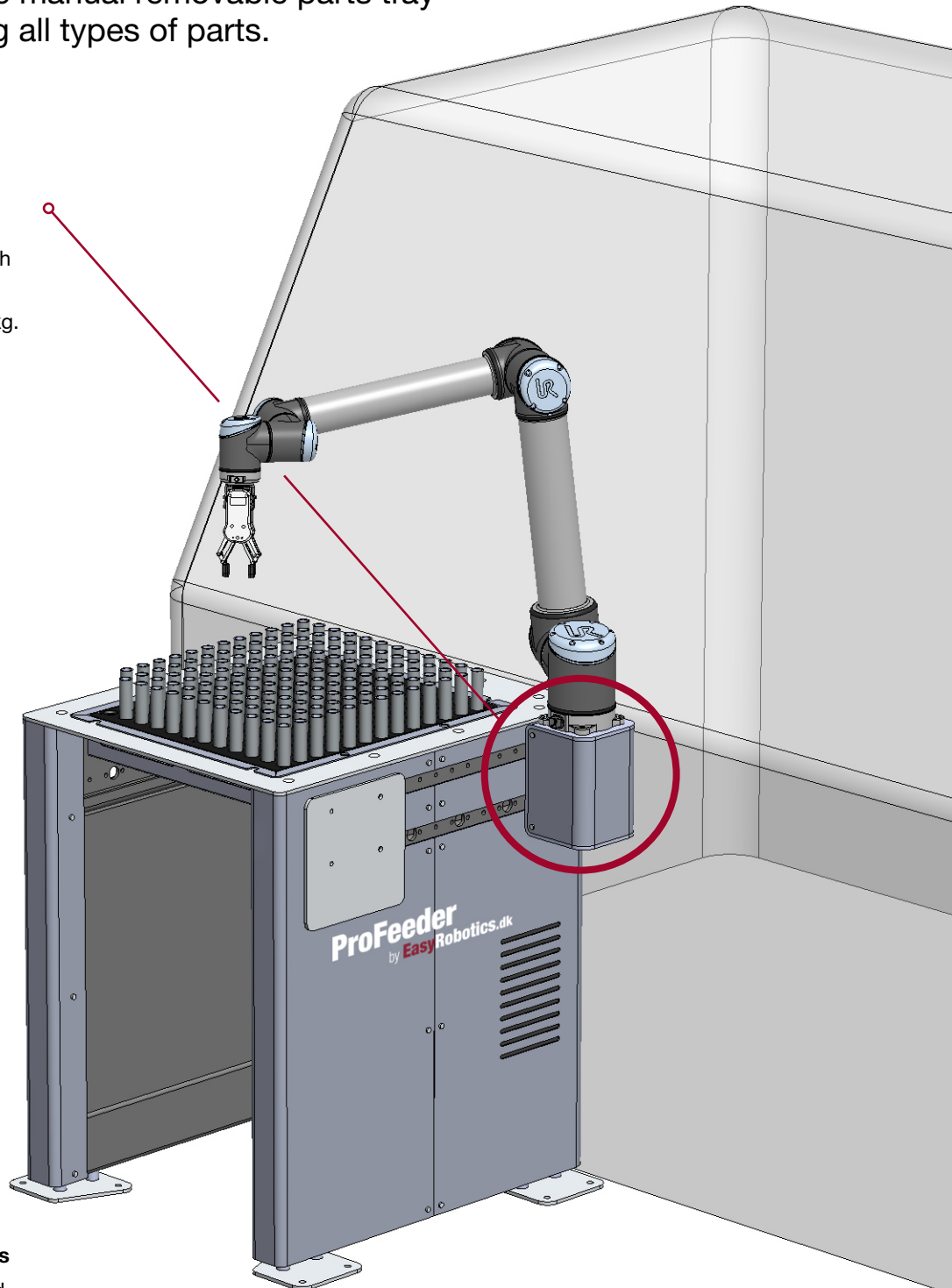

## Staged investment

The basic module, ProFeeder Light, can be expanded to ProFeeder and ProFeeder Multi, when increased capacity is needed.

## Small and quick series changes

- ProFeeder Light can be moved easily with a pallet truck.
- The parts tray can be changed quickly and manually.

## FACTS

### An extra pair of hands for smaller series production

The price of ProFeeder Light allows it to be used as an "extra pair of hands" to be deployed for smaller series or as the first step towards fully automated production.

# ProFeeder

The ProFeeder robot cell consists of one basic module, 2 movers with 2 flexible part trays. The part trays are automatically centred, and are designed to accommodate all part types.

## Increased production

- The solution makes it possible to introduce light out production; the operator is informed of downtime by a text message.

## Good investment

- The typical return on investment is less than 1 year.

## Quick series changes

- ProFeeder is easily moved with a pallet truck.
- Quick change over time makes ProFeeder suitable for small and medium production series.

## Increased efficiency

- Automated supply to the CNC machine ensures consistent high quality. The required man hours for operation can be reduced from 8 hours to less than 1 hour.

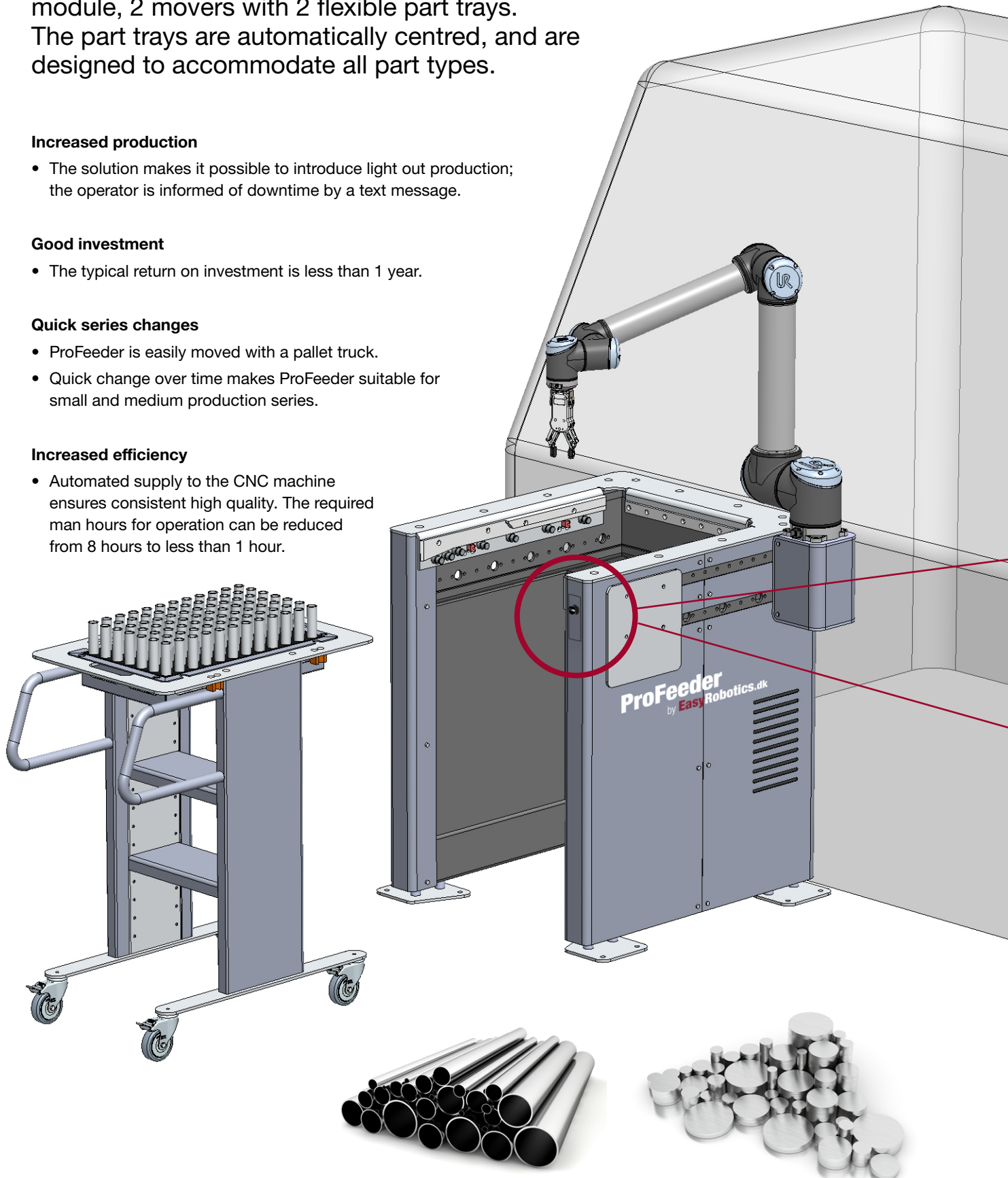

The part trays are designed to accommodate all parts types.

## ProFeeder – safe operation and easy changes.

### The mover and automatic centring of parts

- The mover is a modular built cart that can be upgraded with additional features, when ProFeeder is expanded to ProFeeder Multi.
- When the mover is placed in the robot cell, the parts trays are automatically centred relative to the robot.
- The parts are transported around in the production by the mover which is easy to push even when the part trays are filled.

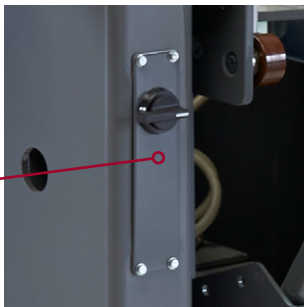

### Plug and Produce

- Plug in the air hose.
- Turn the bottom, the part tray is centered and production ready.



### Expansion options

- The robot cell is supplied with a holder for the robot's control panel.

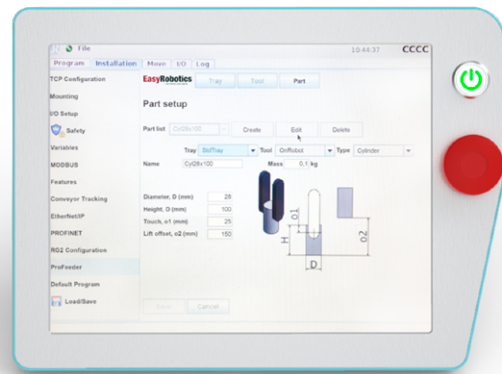

## ProFeeder Easy+ Software

- EASY+ is an entirely new palletising concept that dramatically reduces the setup-time for new parts. Ready for production in just a few minutes.
- With EASY+ You tell the robot WHAT You want it to do. Our software figures out HOW to do it.
- EASY+ gives customers running 'High Mix / Low Volume' a remarkable advantage.
- Try it for free with your first ProFeeder.

### Features and benefits

- Very rapid configuration of new parts.
- No programming required for new parts.
- EASY+ is available for all Universal Robots (UR3, UR5, UR10).
- Complete video tutorial and all documentation is instantly available by scanning a QR code on the side of all our products.

### How does it work?

- EASY+ is a UR+ software plug-in that's integrated with the standard robot software.
- With EASY+ You specify the robot tool, the part tray and the shape of the part. EASY+ then calculates all the right moves for the robot.
- Tools, trays and parts are all stored in a built-in database for quick retrieval and reuse.
- EASY+ is machine tending made EASY.

### FACTS

**Enables unmanned night shifts, where downtime is notified by a text message.**

# ProFeeder Multi

ProFeeder Multi is expanded with a lift module that automatically switches the trays with the parts to be processed. The capacity is increased from 1 to 8 part trays.

The solution makes it possible to run a fully automated 4-shift operation, or introduce unmanned night shifts where any downtime is notified by a text message.

The manual input is limited to supervising the machine, pre-filling the parts trays and replacing the mover once per 4-shift operation.

## ProFeeder Multi

- The return on investment is approx. 1.5 – 2 years.
- Provides the ability to run a fully automated 4-shift operation.
- Suitable for larger production series.

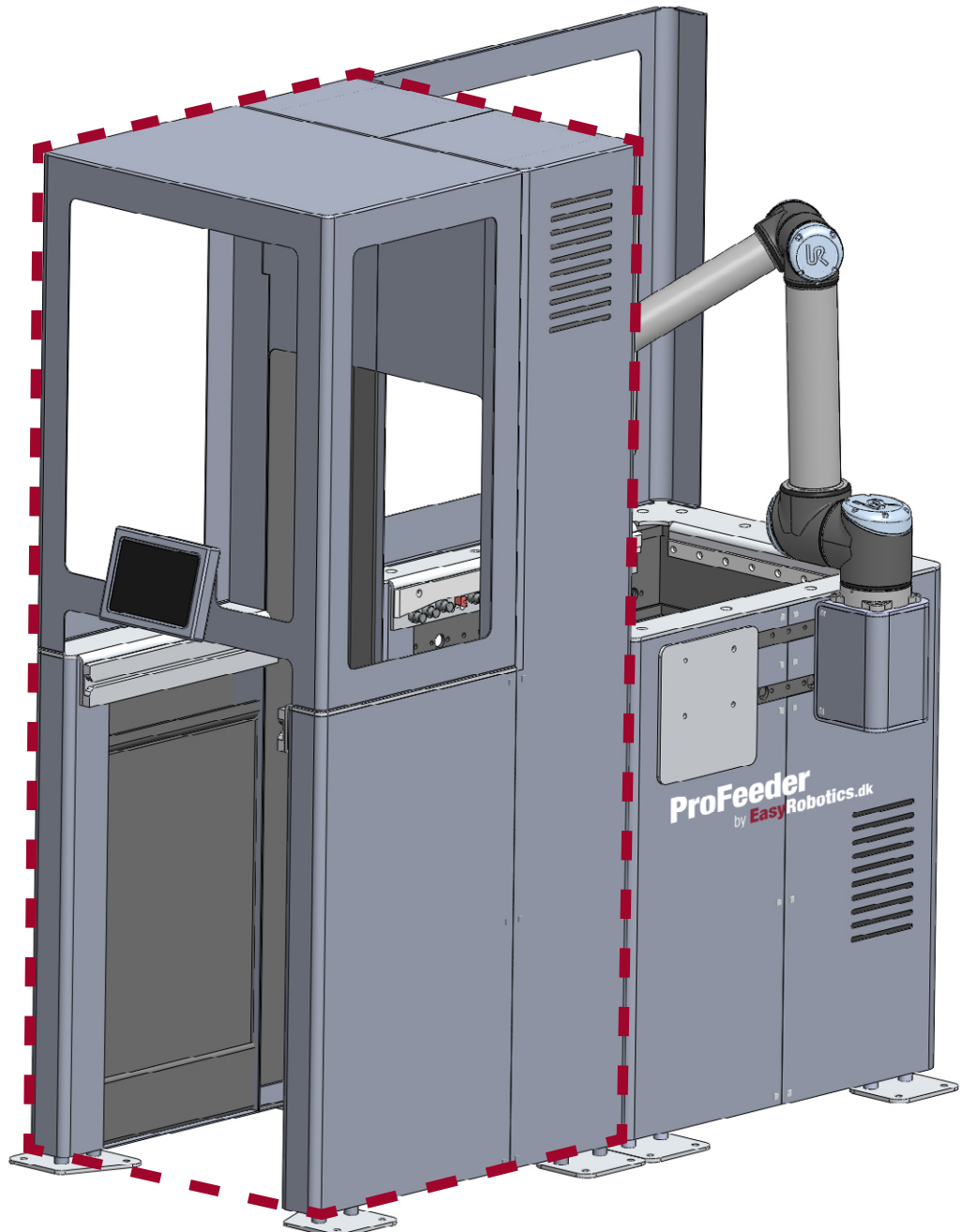
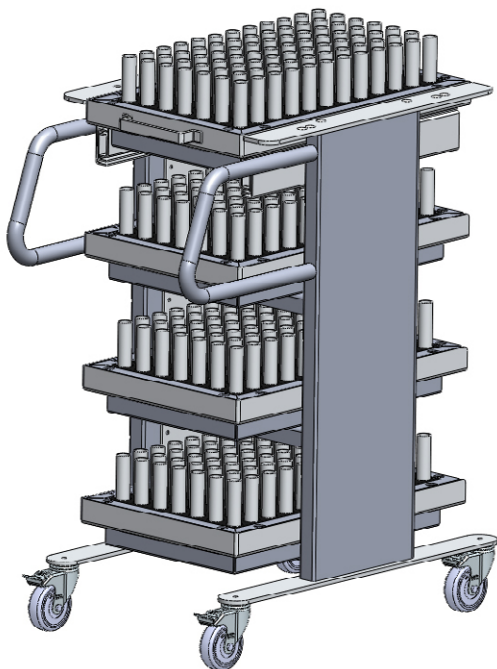

## FACTS

**Egersund Maskinfabrik has gone from 16 hours to less than 1 hours of manning their CNC machine.**

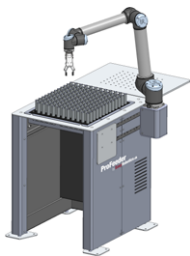
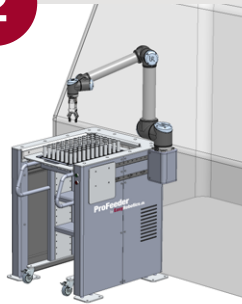
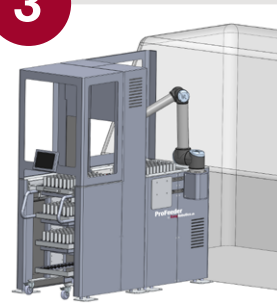
**1****2****3**

	<b>ProFeeder Light</b>	<b>ProFeeder</b>	<b>ProFeeder Multi</b>
<b>Return of investment*</b>	6 – 8 months	Less than 1 year	1.5 – 2 years
<b>Operation of parts trays</b>	Manual change of parts trays	Changing the mover	Fully automated
<b>Mobility</b>	Easily removable	Easily removable	Stationary
<b>Series size</b>	Small series	Small and medium series	Larger series
<b>Number of parts trays</b>	1	2	2 x 10
<b>Movers</b>	-	2	2
<b>Production</b>	An "extra hand"	2-shift operation	Fully automated 4-shift operation
<b>How to order</b>	PFL 1001	PF 1002	PFM 1003
<b>L x W x H</b>	900 x 860 x 925 mm	900 x 860 x 925 mm	1780 x 860 x 2170 mm

\* At 2-shift operation

Patent Pending

## ProFeeder U-Cell

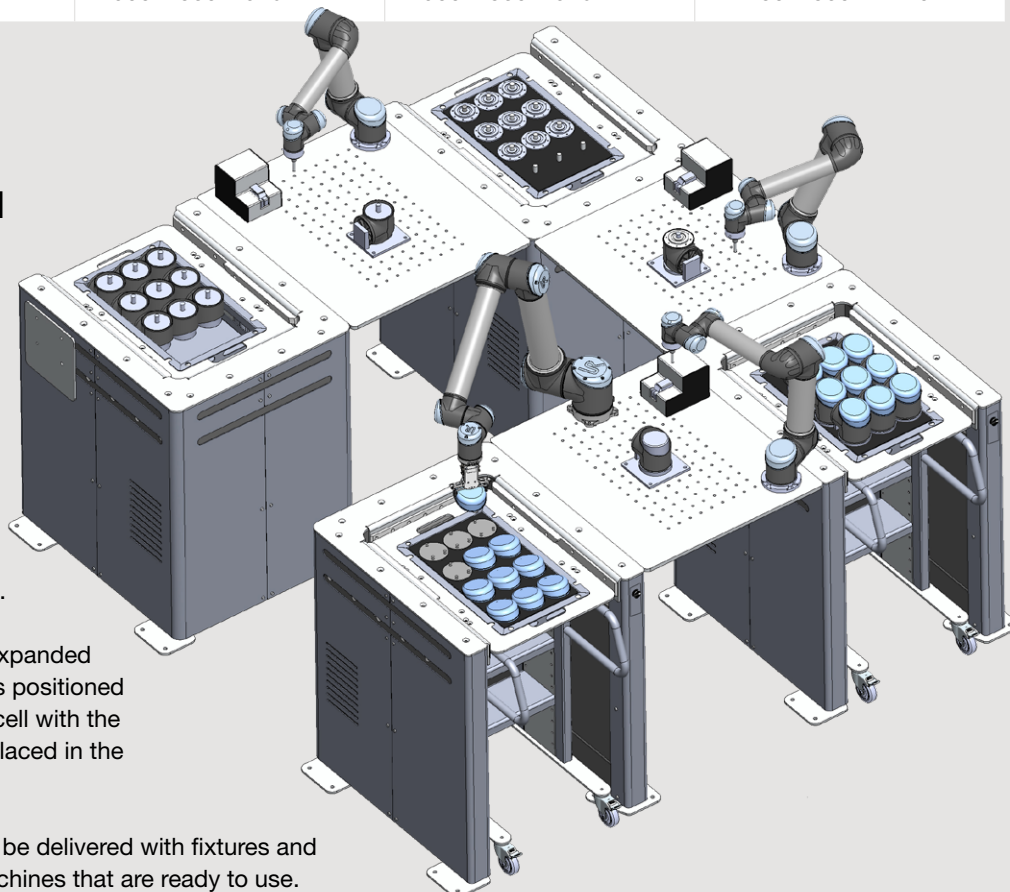

ProFeeder can be integrated as a module in all types of assembly cells.

The cell build-up can be expanded continuously. The mover is positioned manually to and from the cell with the required parts which are placed in the parts trays.

The ProFeeder U-Cell can be delivered with fixtures and robots with e.g. screw machines that are ready to use.



*Easy documentation,  
scan QR-code.*

ER201804

*Danish manufacturer and supplier of robotic  
cells for all types of automation.*

**EasyRobotics**  
- we move your parts

EasyRobotics ApS  
Ellegårdvej 36  
DK-6400 Sønderborg  
Telefon: +45 73 12 42 03  
info@easyrobotics.dk  
[www.easyrobotics.dk](http://www.easyrobotics.dk)

